

Instructions – Parts List

ALUMINUM AND STAINLESS STEEL

Husky™ 1040 Air-Operated Diaphragm Pumps

308479ZAD

ENG

1-inch AODD pump for fluid transfer applications.
For professional use only.

See Models on page 2 for a list of pump models and descriptions.

120 psi (0.8 MPa, 8 bar) Maximum Fluid Working Pressure
120 psi (0.8 MPa, 8 bar) Maximum Air Input Pressure

Patent No.
CN ZL94102643.4
FR 9408894
JA 3517270
US 5,368,452



Important Safety Instructions

Read all warnings and instructions in the manual.
Save these instructions.

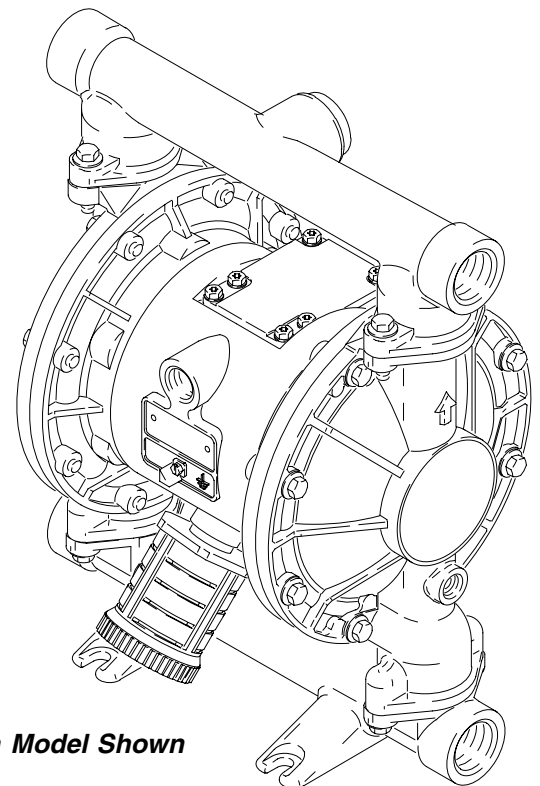

Aluminum Model Shown

02632C



PROVEN QUALITY. LEADING TECHNOLOGY.

Table of Contents

Models	2	Pump Matrix	26
Safety Warnings	3	Repair Kit Matrix	27
Symbols	3	Parts	28
Installation	5	Torque Sequence	33
Operation	12	Dimensional Drawings	34
Maintenance	13	Technical Data and Performance Chart	37
Troubleshooting	14	Graco Standard Warranty	38
Service	16	Graco Information	38

Models

Model No.	Description
*D73_____	Aluminum Pumps
*D83_____	Aluminum Pumps, Remote
*D74_____	Stainless Steel Pumps
*D84_____	Stainless Steel Pumps, Remote
*D7C_____	Aluminum BSPT Pumps
*D8C_____	Aluminum BSPT Pumps, Remote
*D7D_____	Stainless Steel BSPT Pumps
*D8D_____	Stainless Steel BSPT Pumps, Remote
*DR4_____	Stainless Steel Plus Pumps
*DS4_____	Stainless Steel Plus Pumps, Remote
*DRD_____	Stainless Steel BSPT Plus Pumps
*DSD_____	Stainless Steel BSPT Plus Pumps, Remote
232501	Private-Label Aluminum 1040 Pump (See page 26.) (not certified; see note below.)
234124	Private-Label Aluminum 1040 Pump (See page 26.)
246685	Aluminum Pump with Stainless Steel seats and balls, and PTFE diaphragms (See page 24.)
24B778	Stainless Steel Plus Pump with overmolded diaphragms
24B779	Stainless Steel Pump with overmolded diaphragms

***NOTE:** Refer to the Pump Matrix on page 26 to determine the Model No. of your pump.

NOTE: Plus Models include stainless steel center sections.

CERTIFICATION NOTE: Pump Model 232501 is not  certified.

Symbols

Warning Symbol



This symbol alerts you to the possibility of serious injury or death if you do not follow the instructions.

Caution Symbol



This symbol alerts you to the possibility of damage to or destruction of equipment if you do not follow the instructions.

! WARNING



INSTRUCTIONS

EQUIPMENT MISUSE HAZARD

Equipment misuse can cause the equipment to rupture or malfunction and result in serious injury.

- This equipment is for professional use only.
- Read all instruction manuals, tags, and labels before operating the equipment.
- Use the equipment only for its intended purpose. If you are not sure, call your Graco distributor.
- Do not alter or modify this equipment. Use only genuine Graco parts and accessories.
- Check equipment daily. Repair or replace worn or damaged parts immediately.
- Do not exceed the maximum working pressure of the lowest rated component in your system. This equipment has a **120 psi (0.8 MPa, 8 bar) maximum working pressure at 120 psi (0.8 MPa, 8 bar) maximum incoming air pressure.**
- Use fluids and solvents which are compatible with the equipment wetted parts. Refer to the **Technical Data** section of all equipment manuals. Read the fluid and solvent manufacturer's warnings.
- Do not use 1,1,1-trichloroethane, methylene chloride, other halogenated hydrocarbon solvents or fluids containing such solvents in pressurized aluminum equipment. Such use could result in a chemical reaction, with the possibility of explosion.
- Do not use hoses to pull equipment.
- Route hoses away from traffic areas, sharp edges, moving parts, and hot surfaces. Do not expose Graco hoses to temperatures above 82°C (180°F) or below -40°C (-40°F).
- Do not lift pressurized equipment.
- Comply with all applicable local, state, and national fire, electrical, and safety regulations.

WARNING



TOXIC FLUID HAZARD

Hazardous fluid or toxic fumes can cause serious injury or death if splashed in the eyes or on the skin, inhaled, or swallowed.

- Know the specific hazards of the fluid you are using.
- Store hazardous fluid in an approved container. Dispose of hazardous fluid according to all local, state and national guidelines.
- Always wear protective eyewear, gloves, clothing and respirator as recommended by the fluid and solvent manufacturer.
- Pipe and dispose of the exhaust air safely, away from people, animals, and food handling areas. If the diaphragm fails, the fluid is exhausted along with the air. See **Air Exhaust Ventilation** on page 10.



FIRE AND EXPLOSION HAZARD

Improper grounding, poor ventilation, open flames or sparks can cause a hazardous condition and result in a fire or explosion and serious injury.

- Ground the equipment. Refer to **Grounding** on page 5.
- If there is any static sparking or you feel an electric shock while using this equipment, **stop pumping immediately**. Do not use the equipment until you identify and correct the problem.
- Provide fresh air ventilation to avoid the buildup of flammable fumes from solvents or the fluid being sprayed.
- Pipe and dispose of the exhaust air safely, away from all sources of ignition. If the diaphragm fails, the fluid is exhausted along with the air. See **Air Exhaust Ventilation** on page 10.
- Keep the work area free of debris, including solvent, rags, and gasoline.
- Electrically disconnect all equipment in the work area.
- Extinguish all open flames or pilot lights in the work area.
- Do not smoke in the work area.
- Do not turn on or off any light switch in the work area while operating or if fumes are present.
- Do not operate a gasoline engine in the work area.

Installation

General Information

- The Typical Installations shown in Figs. 2–4 are only guides for selecting and installing system components. Contact your Graco distributor for assistance in planning a system to suit your needs.
- Always use Genuine Graco Parts and Accessories. Refer to Product Data Sheet 305588.
- Reference numbers and letters in parentheses refer to the callouts in the figures and the parts lists on pages 28–30.

! WARNING

TOXIC FLUID HAZARD
Hazardous fluid or toxic fumes can cause serious injury or death if splashed in the eyes or on the skin, inhaled, or swallowed.



1. Read **TOXIC FLUID HAZARD** on page 4.
2. Use fluids and solvents which are compatible with the equipment wetted parts. Refer to the **Technical Data** section of all equipment manuals. Read the fluid and solvent manufacturer's warnings.

Tightening Screws Before First Use

Before using the pump for the first time, check and retorque all external fasteners. See **Torque Sequence**, page 33. After the first day of operation, retorque the fasteners. Although pump use varies, a general guideline is to retorque fasteners every two months.

Grounding

! WARNING

FIRE AND EXPLOSION HAZARD
This pump must be grounded. Before operating the pump, ground the system as explained below. Also, read the section **FIRE AND EXPLOSION HAZARD**, on page 4.



To reduce the risk of static sparking, ground the pump and all other equipment used or located in the pumping area. Check your local electrical code for detailed grounding instructions for your area and type of equipment. **Ground all of this equipment.**

- *Pump:* Connect a ground wire and clamp as shown in Fig. 1. Loosen the grounding screw (W). Insert one end of a 12 ga (1.5 mm²) minimum ground wire (Y) behind the grounding screw and tighten the screw securely. Connect the clamp end of the ground wire to a true earth ground. Order Part No. 222011 Ground Wire and Clamp.

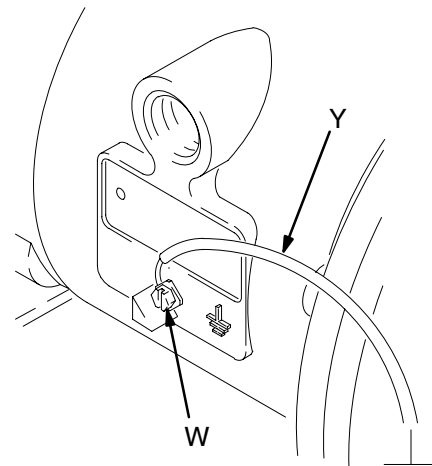

Fig. 1

02646B

- *Air and fluid hoses:* Use only grounded hoses with a maximum of 500 ft (150 m) combined hose length to ensure grounding continuity.
- *Air compressor:* Follow the manufacturer's recommendations.
- *All solvent pails used when flushing:* Follow the local code. Use only metal pails, which are conductive. Do not place the pail on a non-conductive surface, such as paper or cardboard, which interrupts the grounding continuity.
- *Fluid supply container:* Follow the local code.

Installation

Mountings

CAUTION

The pump exhaust air may contain contaminants. Ventilate to a remote area if the contaminants could affect your fluid supply. See **Air Exhaust Ventilation** on page 10.

- Be sure the mounting surface can support the weight of the pump, hoses, and accessories, as well as the stress caused during operation.
- For all mountings, be sure the pump is bolted directly to the mounting surface.
- For ease of operation and service, mount the pump so the air valve cover (2), air inlet, and fluid inlet and outlet ports are easily accessible.
- Rubber Foot Mounting Kit 236452 is available to reduce noise and vibration during operation.

Air Line

WARNING

A bleed-type master air valve (B) is required in your system to relieve air trapped between this valve and the pump. Trapped air can cause the pump to cycle unexpectedly, which could result in serious injury, including splashing in the eyes or on the skin, injury from moving parts, or contamination from hazardous fluids. See Fig. 3.

1. Install the air line accessories as shown in Figs. 2–4 on pages 7 and 9. Mount these accessories on the wall or on a bracket. Be sure the air line supplying the accessories is grounded.
 - a. Install an air regulator (C) and gauge to control the fluid pressure. The fluid outlet pressure will be the same as the setting of the air regulator.
 - b. Locate one bleed-type master air valve (B) close to the pump and use it to relieve trapped air. See the **WARNING** above. Locate the other master air valve (E) upstream from all air line accessories and use it to isolate them during cleaning and repair.

- c. The air line filter (F) removes harmful dirt and moisture from the compressed air supply.

2. Install a grounded, flexible air hose (A) between the accessories and the 1/2 npt(f) pump air inlet (N). See Fig. 5. Use a minimum 3/8" (9.5 mm) ID air hose. Screw an air line quick disconnect coupler (D) onto the end of the air hose (A), and screw the mating fitting into the pump air inlet snugly. Do not connect the coupler (D) to the fitting until you are ready to operate the pump.

Installation of Remote Pilot Air Lines

1. Refer to Parts Drawings. Connect air line to pump as in preceding steps.
2. Connect 1/4 in. O.D. tubing to push type connectors (14) on air motor of pump.

NOTE: by replacing the push type connectors, other sizes or types of fittings may be used. The new fittings will require 1/8 in. npt threads.

3. Connect remaining ends of tubes to external air signal, such as Graco's Cycleflo (P/N 195264) or Cycleflo II (P/N195265) controllers.

NOTE: the air pressure at the connectors must be at least 30% of the air pressure to the air motor for the pump to operate.

Fluid Suction Line

1. Use grounded fluid hoses. The pump fluid inlet (R) is 1" npt(f). See Fig. 5. Screw the fluid fitting into the pump inlet securely.
2. If the fluid inlet pressure to the pump is more than 25% of the outlet working pressure, the ball check valves will not close fast enough, resulting in inefficient pump operation.
3. At inlet fluid pressures greater than 15 psi (0.1 MPa, 1 bar), diaphragm life will be shortened.
4. See the **Technical Data** on page 37 for maximum suction lift (wet and dry).

Installation

Fluid Outlet Line

WARNING

A fluid drain valve (J) is required to relieve pressure in the hose if it is plugged. The drain valve reduces the risk of serious injury, including splashing in the eyes or on the skin, or contamination from hazardous fluids when relieving pressure. Install the valve close to the pump fluid outlet. See Fig. 3.

1. Use grounded fluid hoses (L). The pump fluid outlet (S) is 1" npt(f). See Fig. 5. Screw the fluid fitting into the pump outlet securely.
2. Install a fluid drain valve (J) near the fluid outlet. See the **WARNING** above, and Figs. 2–4 on pages 7 and 9.
3. Install a shutoff valve (K) in the fluid outlet line.

KEY FOR FIG. 2

- A Air supply line
- B Bleed-type master air valve (required for pump)
- C Air regulator
- D Air line quick disconnect
- E Master air valve (for accessories)
- F Air line filter
- G Fluid suction line
- H Bung adapter
- J Fluid drain valve (required)
- K Fluid shutoff valve
- L Fluid line
- Y Ground wire (required; see page 5 for installation instructions)

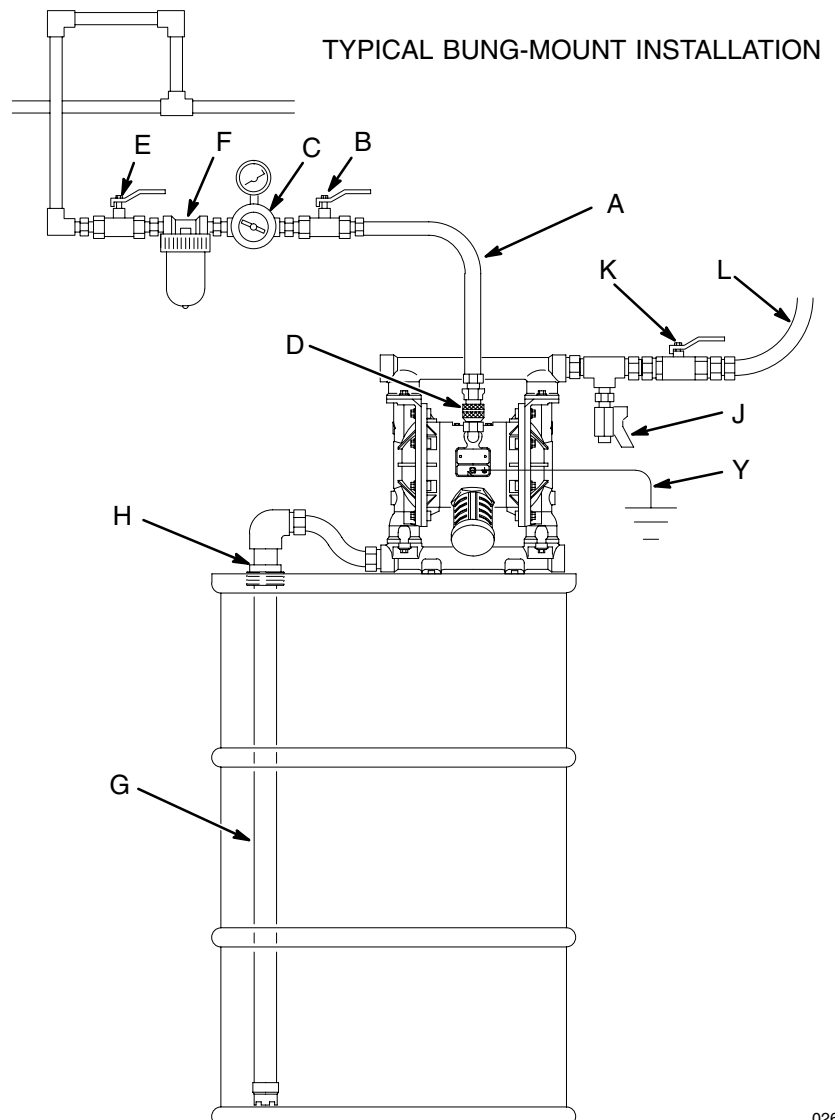

Fig. 2

02648B

TYPICAL FLOOR-MOUNT INSTALLATION

KEY FOR FIG. 3

- A Air supply line
- B Bleed-type master air valve (required for pump)
- C Air regulator
- D Air line quick disconnect
- E Master air valve (for accessories)
- F Air line filter
- G Fluid suction line
- J Fluid drain valve (required)
- K Fluid shutoff valve
- L Fluid line
- Y Ground wire (required; see page 5 for installation instructions)

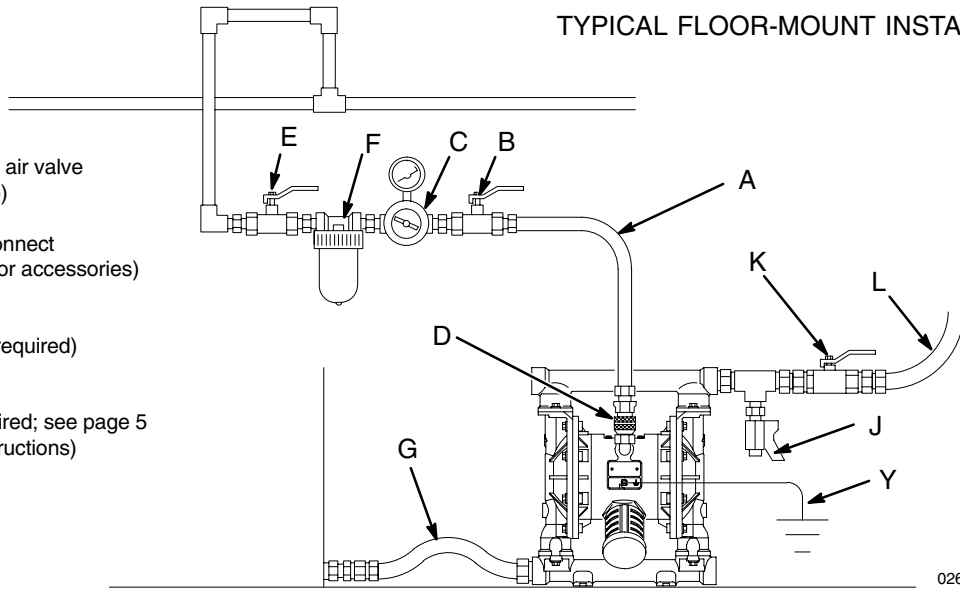

Fig. 3

02651B

Installation

KEY FOR FIG. 4

- A Air supply line
- B Bleed-type master air valve (required for pump)
- C Air regulator
- D Air line quick disconnect
- E Master air valve (for accessories)
- F Air line filter
- G Fluid suction line
- J Fluid drain valve (required)
- K Fluid shutoff valve
- L Fluid line
- M Wall mounting bracket
- Y Ground wire (required; see page 5 for installation instructions)

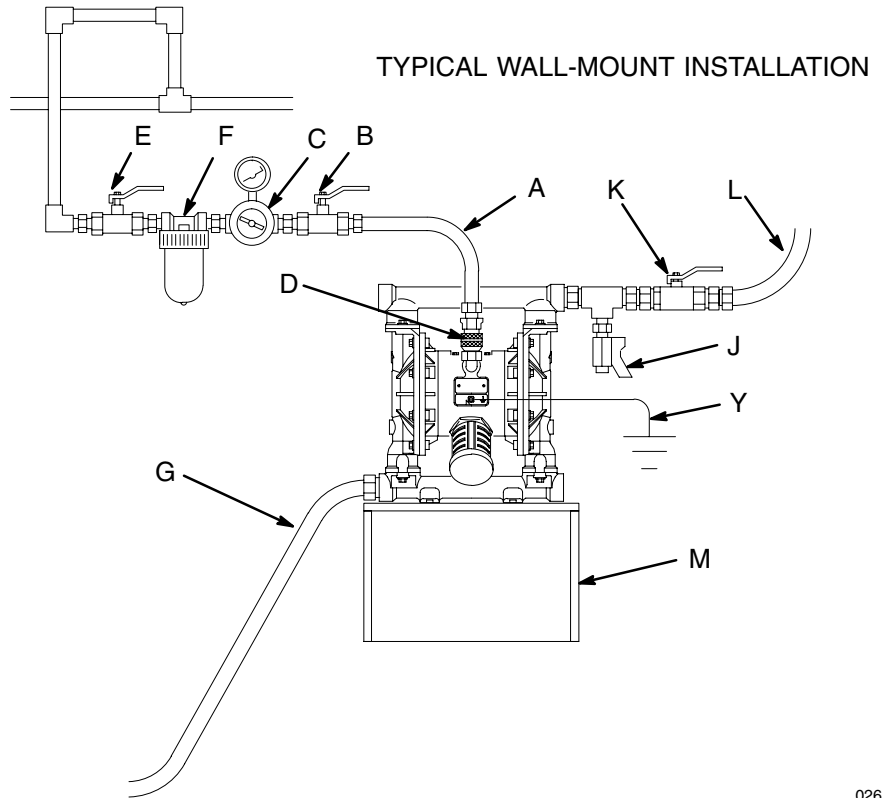

Fig. 4

02649B

Changing the Orientation of the Fluid Inlet and Outlet Ports

On aluminum pumps, the fluid inlet and outlet manifolds have threaded ports on both ends. The pump is shipped with a plug installed in one end of each manifold, and the opposite end open. See Fig. 5. To change the orientation of the inlet and/or outlet port, remove the plug from one end of a manifold and install it in the opposite end.

On stainless steel pumps, the fluid inlet and outlet manifolds have threaded ports on one end only. The pump is shipped with the ports facing the same direction. To reverse the orientation of the ports:

1. Remove the screws and nuts holding the inlet and/or outlet manifold to the covers.
2. Reverse the manifold and reattach. Install the screws and torque to 120–150 in-lb (14–17 N•m). See **Torque Sequence**, page 33.

KEY

- N 1/2 npt(f) air inlet port
- P Muffler. Air exhaust port is 3/4 npt(f)
- R 1 npt(f) fluid inlet port
- S 1 npt(f) fluid outlet port
- 106 Manifold and cover screws
- 3 Air valve screws

1 Apply medium-strength (blue) Loctite® or equivalent to the threads, and torque to 120–150 in-lb (14–17 N•m). See **Torque Sequence**, page 33.

2 Torque to 50–60 in-lb (5.6–6.8 N•m).

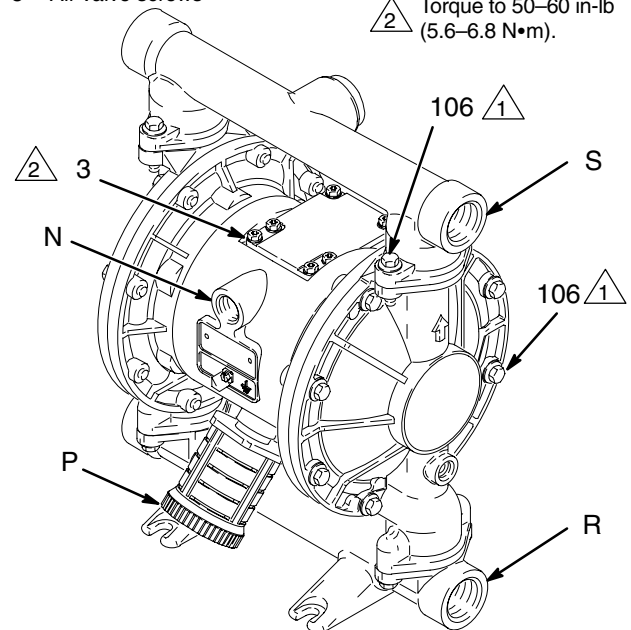

02632C

Fig. 5

Installation

Air Exhaust Ventilation

⚠ WARNING



FIRE AND EXPLOSION HAZARD

Be sure to read and follow the warnings and precautions regarding **TOXIC**



FLUID HAZARD, and FIRE OR EXPLOSION HAZARD on page 4, before operating this pump.

Be sure the system is properly ventilated for your type of installation. You must vent the exhaust to a safe place, away from people, animals, food handling areas, and all sources of ignition when pumping flammable or hazardous fluids.

Diaphragm failure will cause the fluid being pumped to exhaust with the air. Place an appropriate container at the end of the air exhaust line to catch the fluid. See Fig. 6.

The air exhaust port is 3/4 npt(f). Do not restrict the air exhaust port. Excessive exhaust restriction can cause erratic pump operation.

To provide a remote exhaust:

1. Remove the muffler (P) from the pump air exhaust port.
2. Install a grounded air exhaust hose (T) and connect the muffler (P) to the other end of the hose. The minimum size for the air exhaust hose is 3/4 in. (19 mm) ID. If a hose longer than 15 ft (4.57 m) is required, use a larger diameter hose. Avoid sharp bends or kinks in the hose.
3. Place a container (U) at the end of the air exhaust line to catch fluid in case a diaphragm ruptures. See Fig. 6.

VENTING EXHAUST AIR

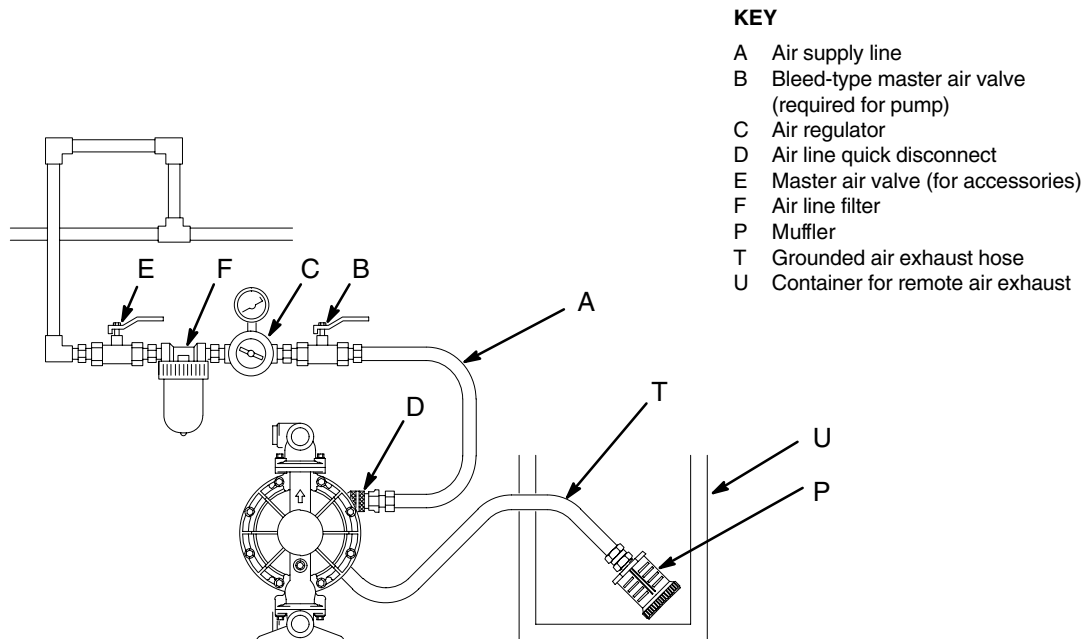

Fig. 6

02650

Installation

Fluid Pressure Relief Kit

⚠ CAUTION

Pressure Relief Kit 238428 (V) is available for Aluminum Pumps, to prevent overpressurization and rupture of the pump or hose. See Fig. 7. The kit includes instructions.

Thermal expansion of fluid in the outlet line can cause overpressurization. This can occur when using long fluid lines exposed to sunlight or ambient heat, or when pumping from a cool to a warm area (for example, from an underground tank).

Overpressurization can also occur if the Husky pump is being used to feed fluid to a piston pump, and the intake valve of the piston pump does not close, causing fluid to back up in the outlet line.

KEY

- R 1 npt(f) optional fluid inlet port
- S 1 npt(f) optional fluid outlet port
- V Pressure relief kit

1 Install kit between fluid inlet and outlet manifolds.

2 Connect fluid inlet line here.

3 Connect fluid outlet line here.

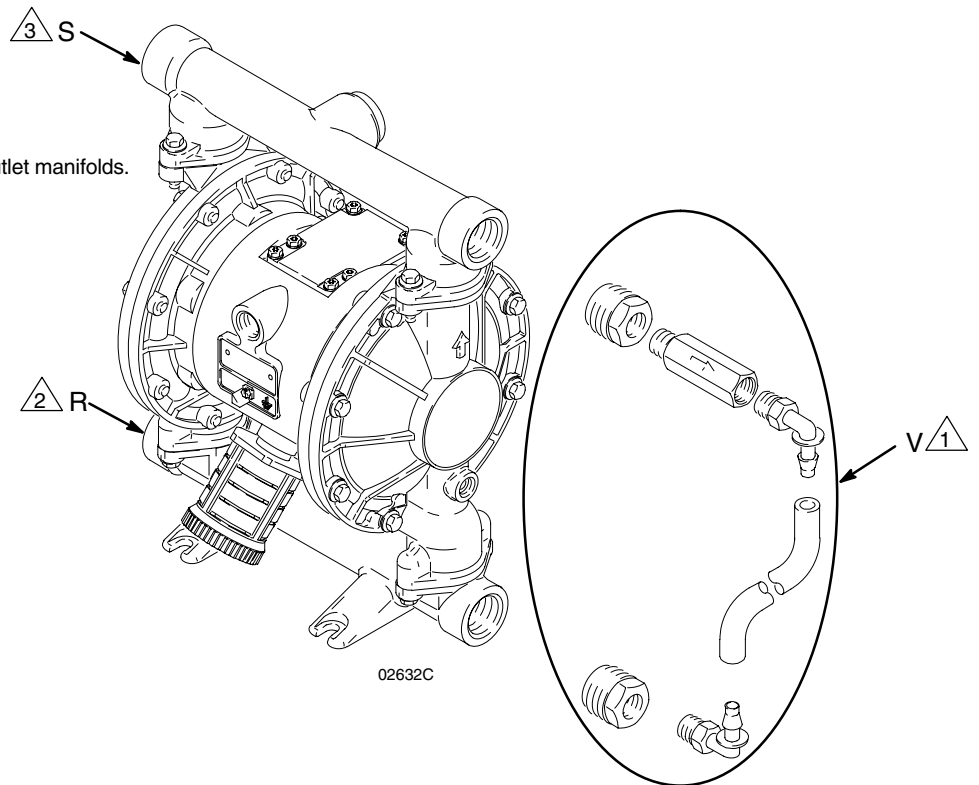

Fig. 7

Operation

Pressure Relief Procedure

WARNING

PRESSURIZED EQUIPMENT HAZARD

The equipment stays pressurized until pressure is manually relieved. To reduce the risk of serious injury from pressurized fluid, accidental spray from the gun or splashing fluid, follow this procedure whenever you

- Are instructed to relieve pressure
- Stop pumping
- Check, clean or service any system equipment
- Install or clean fluid nozzles

1. Shut off the air to the pump.
2. Open the dispensing valve, if used.
3. Open the fluid drain valve to relieve fluid pressure, having a container ready to catch the drainage.

Flush the Pump Before First Use

The pump was tested with lightweight oil, which is left in the fluid passages to protect parts. To avoid contaminating your fluid with oil, flush the pump with a compatible solvent before using the equipment. Follow the steps under **Starting and Adjusting the Pump**.

Starting and Adjusting the Pump

WARNING



TOXIC FLUID HAZARD

To reduce the risk of serious injury, splashing in the eyes or on the skin, and toxic fluid spills, **never** move or lift a pump under pressure. If dropped, the fluid section may rupture. Always follow the **Pressure Relief Procedure Warning** above before lifting the pump.

1. Be sure the pump is properly grounded. Refer to **Grounding** on page 5.
2. Check fittings to be sure they are tight. Use a compatible liquid thread sealant on male threads. Tighten fluid inlet and outlet fittings securely.
3. Place the suction tube (if used) in fluid to be pumped.

NOTE: If fluid inlet pressure to the pump is more than 25% of outlet working pressure, the ball check valves will not close fast enough, resulting in inefficient pump operation.

4. Place the end of fluid hose (L) into an appropriate container.

5. Close the fluid drain valve (J).
6. Back out the air regulator (C) knob, and open all bleed-type master air valves (B, E).
7. If the fluid hose has a dispensing device, hold it open while continuing with the following step.
8. Slowly increase air pressure with the air regulator (C) until the pump starts to cycle. Allow the pump to cycle slowly until all air is pushed out of the lines and the pump is primed.

If you are flushing, run the pump long enough to thoroughly clean the pump and hoses. Close the air regulator. Remove the suction tube from the solvent and place it in the fluid to be pumped.

Operation of Remote Piloted Pumps

1. Follow preceding steps 1 through 7 of **Starting and Adjusting Pump**.
2. Open air regulator (C).

WARNING

The pump may cycle once before the external signal is applied. Injury is possible. If pump cycles, wait until end before proceeding.

3. Pump will operate when air pressure is alternately applied and relieved to push type connectors (14).

NOTE: Leaving air pressure applied to the air motor for extended periods when the pump is not running may shorten the diaphragm life. Using a 3-way solenoid valve to automatically relieve the pressure on the air motor when the metering cycle is complete prevents this from occurring.

Pump Shutdown

WARNING

To reduce the risk of serious injury whenever you are instructed to relieve pressure, always follow the **Pressure Relief Procedure** at left.

At the end of the work shift, relieve the pressure.

Maintenance

Lubrication

The air valve is designed to operate unlubricated, however if lubrication is desired, every 500 hours of operation (or monthly) remove the hose from the pump air inlet and add two drops of machine oil to the air inlet.

CAUTION

Do not over-lubricate the pump. Oil is exhausted through the muffler, which could contaminate your fluid supply or other equipment. Excessive lubrication can also cause the pump to malfunction.

Flushing and Storage

WARNING

To reduce the risk of serious injury whenever you are instructed to relieve pressure, always follow the **Pressure Relief Procedure** on page 12.

Flush the pump often enough to prevent the fluid you are pumping from drying or freezing in the pump and damaging it. Use a compatible solvent.

Always flush the pump and relieve the pressure before storing it for any length of time.

Tightening Threaded Connections

Before each use, check all hoses for wear or damage, and replace as necessary. Check to be sure all threaded connections are tight and leak-free. Check fasteners. Tighten or retorque as necessary. Although pump use varies, a general guideline is to retorque fasteners every two months. See **Torque Sequence**, page 33.

Preventive Maintenance Schedule

Establish a preventive maintenance schedule, based on the pump's service history. This is especially important for prevention of spills or leakage due to diaphragm failure.

Troubleshooting

WARNING

To reduce the risk of serious injury whenever you are instructed to relieve pressure, always follow the **Pressure Relief Procedure** on page 12.

- Relieve the pressure before checking or servicing the equipment.
- Check all possible problems and causes before disassembling the pump.

PROBLEM	CAUSE	SOLUTION
Pump cycles at stall or fails to hold pressure at stall.	Worn check valve balls (301), seats (201) or o-rings (202).	Replace. See page 18.
Pump will not cycle, or cycles once and stops.	Air valve is stuck or dirty.	Disassemble and clean air valve. See page 16. Use filtered air.
	Check valve ball (301) severely worn and wedged in seat (201) or manifold (102 or 103).	Replace ball and seat. See page 18.
	Check valve ball (301) is wedged into seat (201), due to overpressurization.	Install Pressure Relief Valve (see page 11).
	Dispensing valve clogged.	Relieve pressure and clear valve.
Pump operates erratically.	Clogged suction line.	Inspect; clear.
	Sticky or leaking balls (301).	Clean or replace. See page 18.
	Diaphragm ruptured.	Replace. See pages 19–22.
	Restricted exhaust.	Remove restriction.
Air bubbles in fluid.	Suction line is loose.	Tighten.
	Diaphragm ruptured.	Replace. See pages 19–22.
	Loose inlet manifold (102), damaged seal between manifold and seat (201), damaged o-rings (202).	Tighten manifold bolts (106) or replace seats (201) or o-rings (202). See page 18.
	Loose diaphragm shaft bolt (107).	Tighten or replace (pages 19–22).
	Damaged o-ring (108).	Replace. See pages 19–22.

Troubleshooting

PROBLEM	CAUSE	SOLUTION
Fluid in exhaust air.	Diaphragm ruptured.	Replace. See pages 19–22.
	Loose diaphragm shaft bolt (107).	Tighten or replace (pages 19–22).
	Damaged o-ring (108).	Replace. See pages 19–22.
Pump exhausts excessive air at stall.	Worn air valve block (7†■), o-ring (6†■), plate (8■), pilot block (18), u-cups (10), or pilot pin o-rings (17†■).	Repair or replace. See page 16.
	Worn shaft seals (402).	Replace. See pages 19–22.
Pump leaks air externally.	Air valve cover (2) or air valve cover screws (3) are loose.	Tighten screws. See page 16.
	Air valve gasket (4) or air cover gasket (22) is damaged.	Inspect; replace. See pages 16, 23–24.
	Air cover screws (25) are loose.	Tighten screws. See pages 23–24.
Pump leaks fluid externally from ball check valves.	Loose manifolds (102, 103), damaged seal between manifold and seat (201), damaged o-rings (202).	Tighten manifold bolts (106) or replace seats (201) or o-rings (202). See page 18.

Service

Repairing the Air Valve

Tools Required

- Torque wrench
- Torx (T20) screwdriver or 7 mm (9/32") socket wrench
- Needle-nose pliers
- O-ring pick
- Lithium base grease

NOTE: Air Valve Repair Kits 236273 (aluminum center housing models) and 255061 (sst center housing models) are available. Refer to page 27. Parts included in the kit are marked with a symbol, for example (4†■). Use all the parts in the kit for the best results.

Disassembly

WARNING

To reduce the risk of serious injury whenever you are instructed to relieve pressure, always follow the **Pressure Relief Procedure** on page 12.

1. Relieve the pressure.
2. With a Torx (T20) screwdriver or 7 mm (9/32") socket wrench, remove the six screws (3), air valve cover (2), and gasket (4). See Fig. 8.
3. Move the valve carriage (5) to the center position and pull it out of the cavity. Remove the valve block (7†■) and o-ring (6†■) from the carriage. Using a needle-nose pliers, pull the pilot block (18) straight up and out of the cavity. See Fig. 9.
4. Pull the two actuator pistons (11) out of the bearings (12). Remove the u-cup packings (10) from the pistons. Pull the pilot pins (16) out of the bearings (15). Remove the o-rings (17) from the push pins. See Fig. 10.
5. Inspect the valve plate (8■) in place. If damaged, use a Torx (T20) screwdriver or 7 mm (9/32") socket wrench to remove the three screws (3). Remove the valve plate (8■) and, on aluminum center housing models, remove the seal (9). See Fig. 11.
6. Inspect the bearings (12, 15) in place. See Fig. 10. The bearings are tapered and, if damaged, must be removed from the outside. This requires disassembly of the fluid section. See page 23.
7. Clean all parts and inspect for wear or damage. Replace as needed. Reassemble as explained on page 16.

Reassembly

1. *If you replaced the bearings (12, 15),* reinstall as explained on page 23. Reassemble the fluid section.
2. On aluminum center housing models, install the valve plate seal (9†) into the groove at the bottom of the valve cavity. The rounded side of the seal **must face down** into the groove. See Fig. 11.
3. Install the valve plate (8■) in the cavity. On aluminum center housing models, the plate is reversible, so either side can face up. Install the three screws (3), using a Torx (T20) screwdriver or 7 mm (9/32") socket wrench. Tighten until the screws bottom out on the housing. See Fig. 11.
4. Install an o-ring (17†■) on each pilot pin (16). Grease the pins and o-rings. Insert the pins into the bearings (15), **narrow** end first. See Fig. 10.
5. Install a u-cup packing (10†■) on each actuator piston (11), so the lips of the packings face the **narrow** end of the pistons. See Fig. 10.
6. Lubricate the u-cup packings (10†■) and actuator pistons (11). Insert the actuator pistons in the bearings (12), **wide** end first. Leave the narrow end of the pistons exposed. See Fig. 10.
7. Grease the lower face of the pilot block (18†■) and install so its tabs snap into the grooves on the ends of the pilot pins (16). See Fig. 9.
8. Grease the o-ring (6†■) and install it in the valve block (7†■). Push the block onto the valve carriage (5). Grease the lower face of the valve block. See Fig. 9.
9. Install the valve carriage (5) so its tabs slip into the grooves on the narrow end of the actuator pistons (11). See Fig. 9.
10. Align the valve gasket (4†■) and cover (2) with the six holes in the center housing (1). Secure with six screws (3), using a Torx (T20) screwdriver or 7 mm (9/32") socket wrench. Torque to 50–60 in-lb (5.6–6.8 N•m). See Fig. 8.

Service

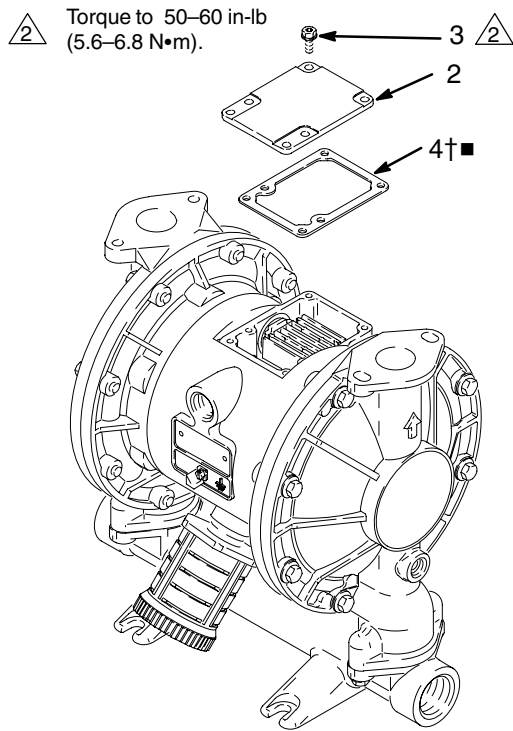

Fig. 8

02644B

- △ 1 Insert narrow end first.
- △ 2 Grease.
- △ 3 Install with lips facing narrow end of piston (11).
- △ 4 Insert wide end first.

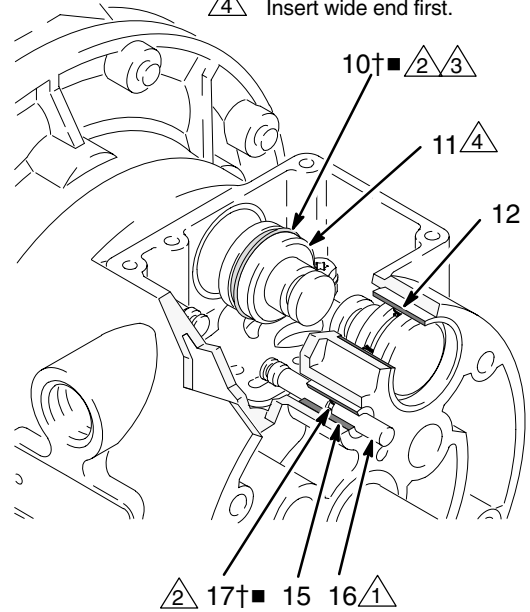

Fig. 10

02643

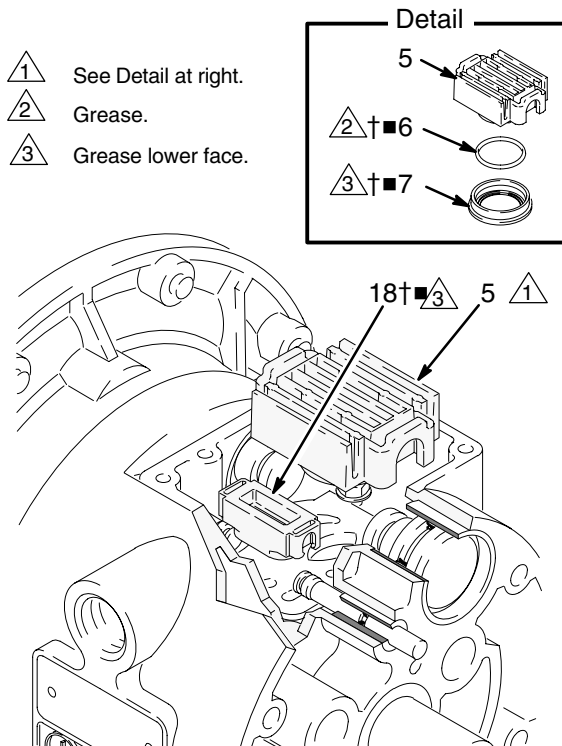

Fig. 9

02642

- △ 1 Rounded side must face down (aluminum center housing models only).
- △ 2 Tighten screws until they bottom out on the housing.

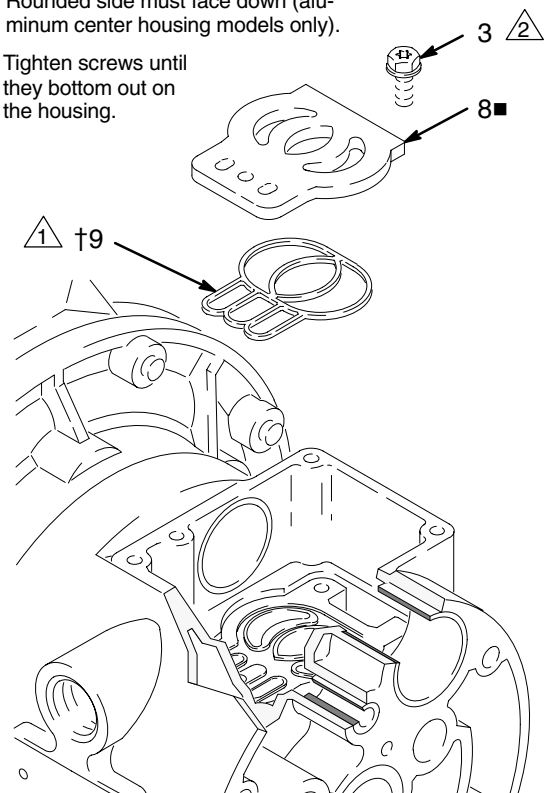

Fig. 11

02645

Service

Ball Check Valve Repair

Tools Required

- Torque wrench
- 10 mm socket wrench
- O-ring pick

Disassembly

NOTE: A Fluid Section Repair Kit is available. Refer to page 27 to order the correct kit for your pump. Parts included in the kit are marked with an asterisk, for example (201*). Use all the parts in the kit for the best results.

NOTE: To ensure proper seating of the balls (301), always replace the seats (201) when replacing the balls. Also, on some models, replace the o-rings (202).

⚠ WARNING

To reduce the risk of serious injury whenever you are instructed to relieve pressure, always follow the **Pressure Relief Procedure** on page 12.

1. Relieve the pressure. Disconnect all hoses.
2. Remove the pump from its mounting.
3. Using a 10 mm socket wrench, remove the four bolts (106) and nuts (114, *used on stainless steel pumps only*) holding the outlet manifold (103) to the fluid covers (101). See Fig. 12.
4. Remove the o-rings (202, *not used on some models*), seats (201), and balls (301) from the manifold (103).
5. Turn the pump over and remove the inlet manifold (102). Remove the o-rings (202, *not used on some models*), seats (201), and balls (301) from the fluid covers (101).

Reassembly

1. Clean all parts and inspect for wear or damage. Replace parts as needed.
2. Reassemble in the reverse order, following all notes in Fig. 12. Be sure the ball checks and manifolds are assembled **exactly** as shown. The arrows (A) on the fluid covers (101) **must** point toward the outlet manifold (103).

- 1 Apply medium-strength (blue) Loctite® or equivalent to the threads, and torque to 120–150 in-lb (14–17 N•m). See **Torque Sequence**, page 33.
- 2 Arrow (A) must point toward outlet manifold (103).
- 3 Beveled seating surface must face the ball (301).
- 4 Not used on some models.

Aluminum Model Shown

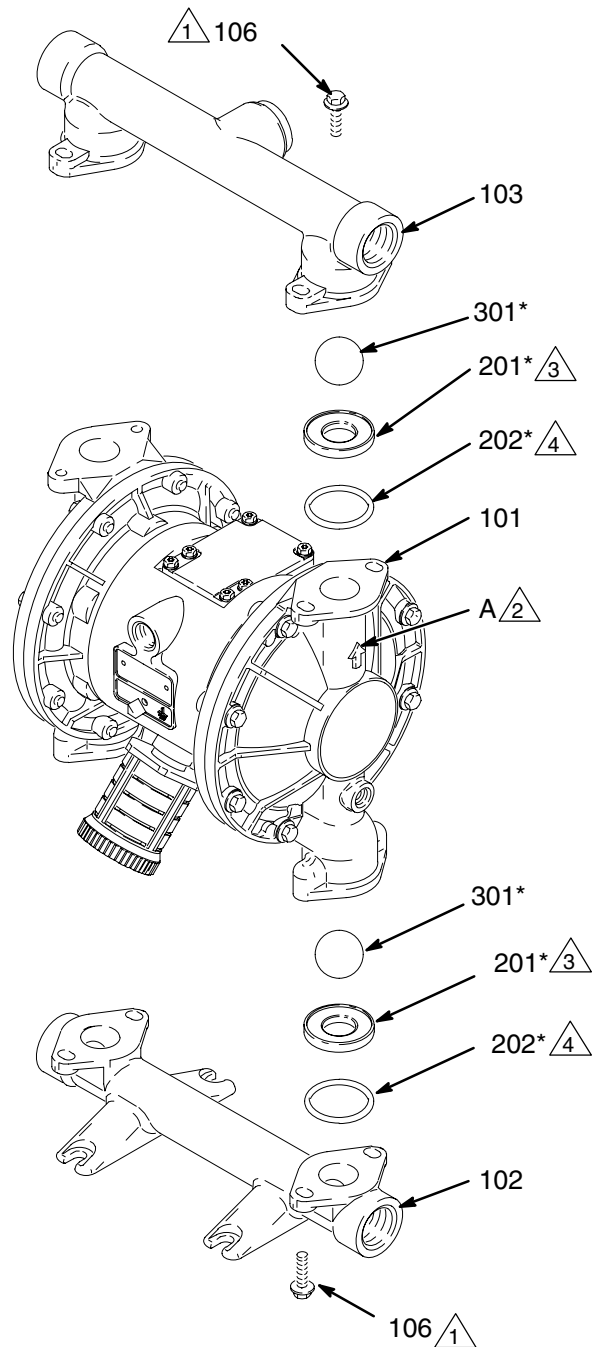

Fig. 12

02647C

Service

Diaphragm Repair

Tools Required

- Torque wrench
- 10 mm socket wrench
- 15 mm socket wrench (aluminum models) or 1" socket wrench (stainless steel models)
- 19 mm open-end wrench
- O-ring pick
- Lithium-base grease

Disassembly

NOTE: A Fluid Section Repair Kit is available. Refer to page 27 to order the correct kit for your pump. Parts included in the kit are marked with an asterisk, for example (401*). Use all the parts in the kit for the best results.

⚠ WARNING

To reduce the risk of serious injury whenever you are instructed to relieve pressure, always follow the **Pressure Relief Procedure** on page 12.

1. Relieve the pressure.
2. Remove the manifolds and disassemble the ball check valves as explained on page 18.
3. Using a 10 mm socket wrench, remove the screws (106) holding the fluid covers (101) to the air covers (23). Pull the fluid covers (101) off the pump. See Fig. 13.

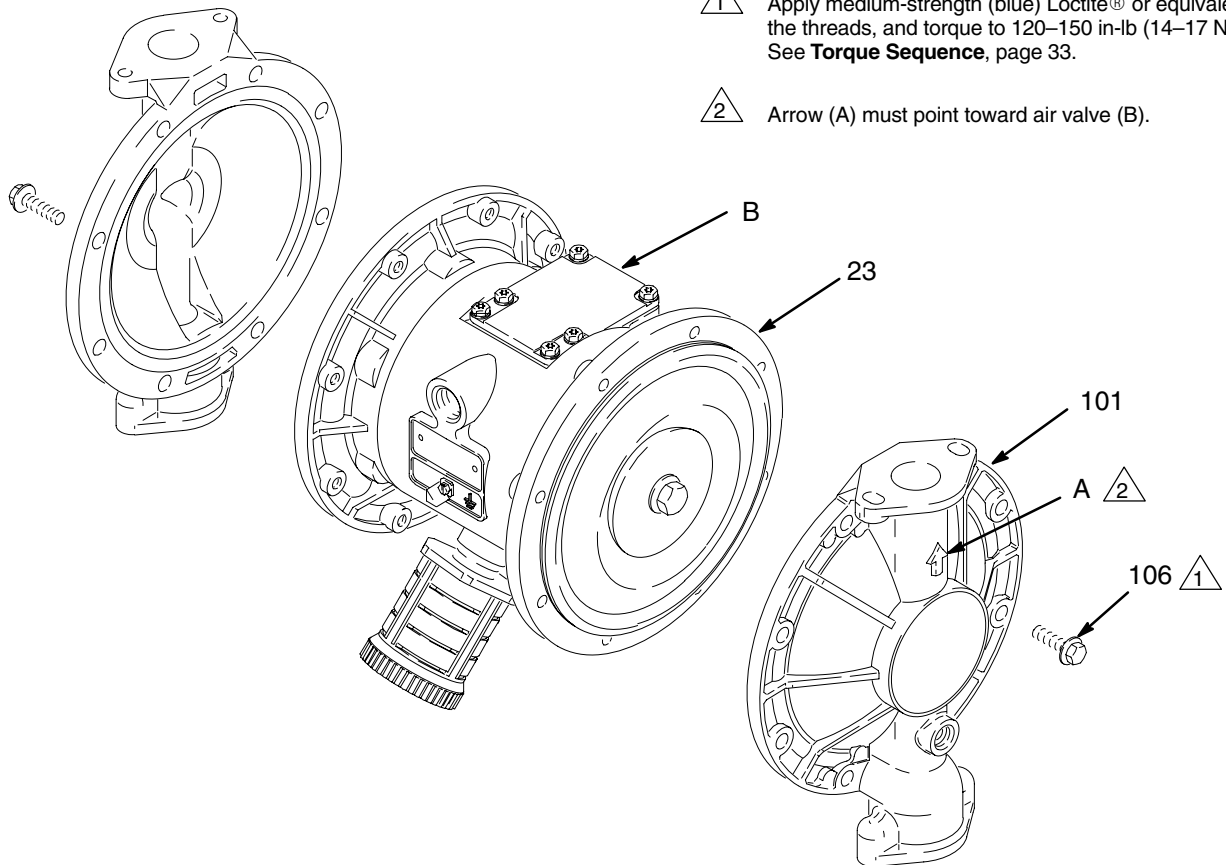

Fig. 13

02635B

Service

- Loosen but do not remove the diaphragm shaft bolts (107), using a 15 mm socket wrench (1" on stainless steel models) on both bolts. *NOTE: This step does not apply to pumps with overmolded diaphragms.*

- Unscrew one bolt from the diaphragm shaft (24) and remove the o-ring (108), fluid side diaphragm plate (105), PTFE diaphragm (403, used on PTFE models only), diaphragm (401), and air side diaphragm plate (104). See Fig. 14.

For overmolded diaphragms: Grip both diaphragms securely around the outer edge and rotate counterclockwise. One diaphragm assembly will come free and the other will remain attached to the shaft. Remove the freed diaphragm and air side plate.

- Pull the other diaphragm assembly and the diaphragm shaft (24) out of the center housing (1). Hold the shaft flats with a 19 mm open-end wrench, and remove the bolt (107) from the shaft. Disassemble the remaining diaphragm assembly.

For overmolded diaphragms: Pull the other diaphragm assembly and the diaphragm shaft (24) out of the center housing (1). Hold the shaft flats with a 19 mm open-end wrench and remove the diaphragm and air side plate from the shaft.

- Inspect the diaphragm shaft (24) for wear or scratches. If it is damaged, inspect the bearings (19) in place. If the bearings are damaged, refer to page 23.
- Reach into the center housing (1) with an o-ring pick and hook the u-cup packings (402), then pull them out of the housing. This can be done with the bearings (19) in place.
- Clean all parts and inspect for wear or damage. Replace parts as needed.

Reassembly – Standard Diaphragms

- Install the shaft u-cup packings (402*) so the lips face **out** of the housing (1). Lubricate the packings. See Fig. 14.
- Install the diaphragm assembly on one end of the shaft (24) as follows. *For pumps with overmolded diaphragms, go directly to step g.*
 - Install the o-ring (108*) on the shaft bolt (107).
 - Install the fluid side diaphragm plate (105) on the bolt so the rounded side faces the diaphragm (401).

NOTE: *On stainless steel pumps only,* the fluid side diaphragm plate (105) is stainless steel. This plate **is not** stamped with its part number. Be sure to install this plate on the fluid side of the diaphragm.

- On PTFE models only,* install the PTFE diaphragm (403*). Make certain the side marked AIR SIDE faces the center housing (1).
- Install the diaphragm (401*) on the bolt. Make certain the side marked AIR SIDE faces the center housing (1).
- Install the air side diaphragm plate (104) so the rounded side faces the diaphragm (401). This plate is used on all models, and is stamped with its part number.
- Apply medium-strength (blue) Loctite® or equivalent to the bolt (107) threads. Screw the bolt into the shaft (24) hand tight.
- For overmolded diaphragms:* See separate reassembly section on next page.

- Grease the length and ends of the diaphragm shaft (24), and slide it through the housing (1).
- Assemble the other diaphragm assembly to the shaft as explained in step 2.
- Hold one shaft bolt (107) with a wrench and torque the other bolt to 20–25 ft-lb (27–34 N•m) at 100 rpm maximum.
- Align the fluid covers (101) and the center housing (1) so the arrows (A) on the covers face the same direction as the air valve (B). Apply medium-strength (blue) Loctite® or equivalent to the threads of the screws (106). Secure the covers with the screws handtight. See Fig. 13. Using a 10 mm socket wrench, torque the screws oppositely and evenly to 120–150 in-lb (14–17 N•m). See **Torque Sequence**, page 33.
- Reassemble the ball check valves and manifolds as explained on page 18.

Reassembly – Overmolded Diaphragms

WARNING

To reduce the risk of serious injury, including amputation, do not put your fingers or hand between the air cover and the diaphragm.

1. Lubricate and install the shaft u-cup packings (402*) so the lips face **out** of the housing (1). See Fig. 13.
 2. Assemble the air side plate (104) onto the diaphragm (403). The wide, radiused side of the plate must face the diaphragm. Apply medium-strength (blue) Loctite or equivalent to the threads of the diaphragm assembly. Screw the assembly into the shaft (24) hand-tight.
 3. Grease the length and ends of the diaphragm shaft (24). Insert the shaft/diaphragm assembly into one side of the pump. Align the fluid cover (101) and the center housing (1) so the arrow (A) faces the same direction as the air valve. Secure the cover with the screws (107 and 108), handtight.
 4. Torque the longer screws (108) oppositely and evenly to 190–220 in-lb (21–25 N•m), using a 13mm socket wrench. Then torque the shorter screws (107). See **Torque Sequence**, page 33.
 5. Assemble the other diaphragm assembly to the shaft as explained in step 2. This diaphragm will be lifted off the air cover at this point.
 6. Supply the pump with low pressure air (less than 7 psi [0.05 MPa, 0.5 bar]). The diaphragm will very slowly pull onto the air cover. Find the pressure that keeps the diaphragm close enough to secure with the screws, but does not let it contact the pilot pin.
- NOTE:** Do not deform the diaphragm manually. The diaphragm needs uniform pressure to deform properly for maximum life.
7. Align the fluid cover (101) and the center housing (1) so the arrow (A) faces the same direction as the air valve. Secure the cover with two of the longer screws (108), handtight.
- NOTE:** If the diaphragm contacts the pilot pin and is forced away from the air cover, try Step 5 again. If necessary, return to Step 3.
8. Torque the longer screws (108) oppositely and evenly to 190–220 in-lb (21–25 N•m), using a 13mm socket wrench. Then torque the shorter screws (107). See **Torque Sequence**, page 33.
 9. Reassemble the ball check valves and manifolds as explained on page 18.

Service

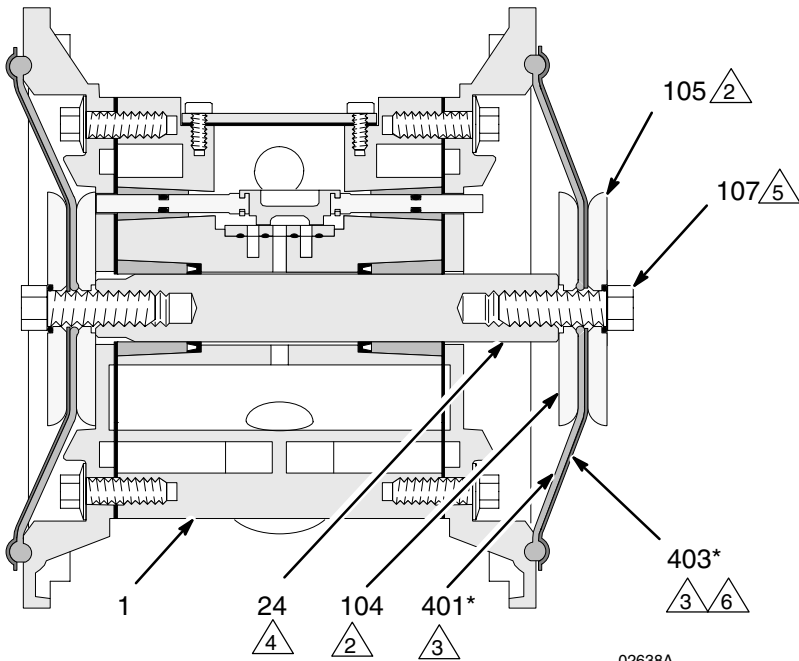

02638A

Cutaway View, with Diaphragms in Place

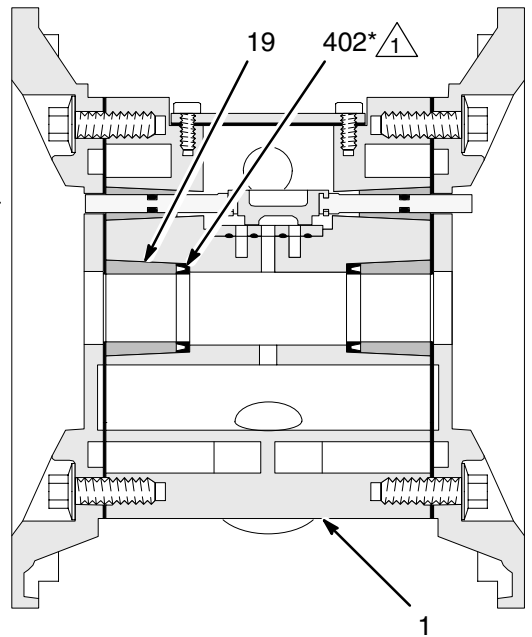

02637A

Cutaway View, with Diaphragms Removed

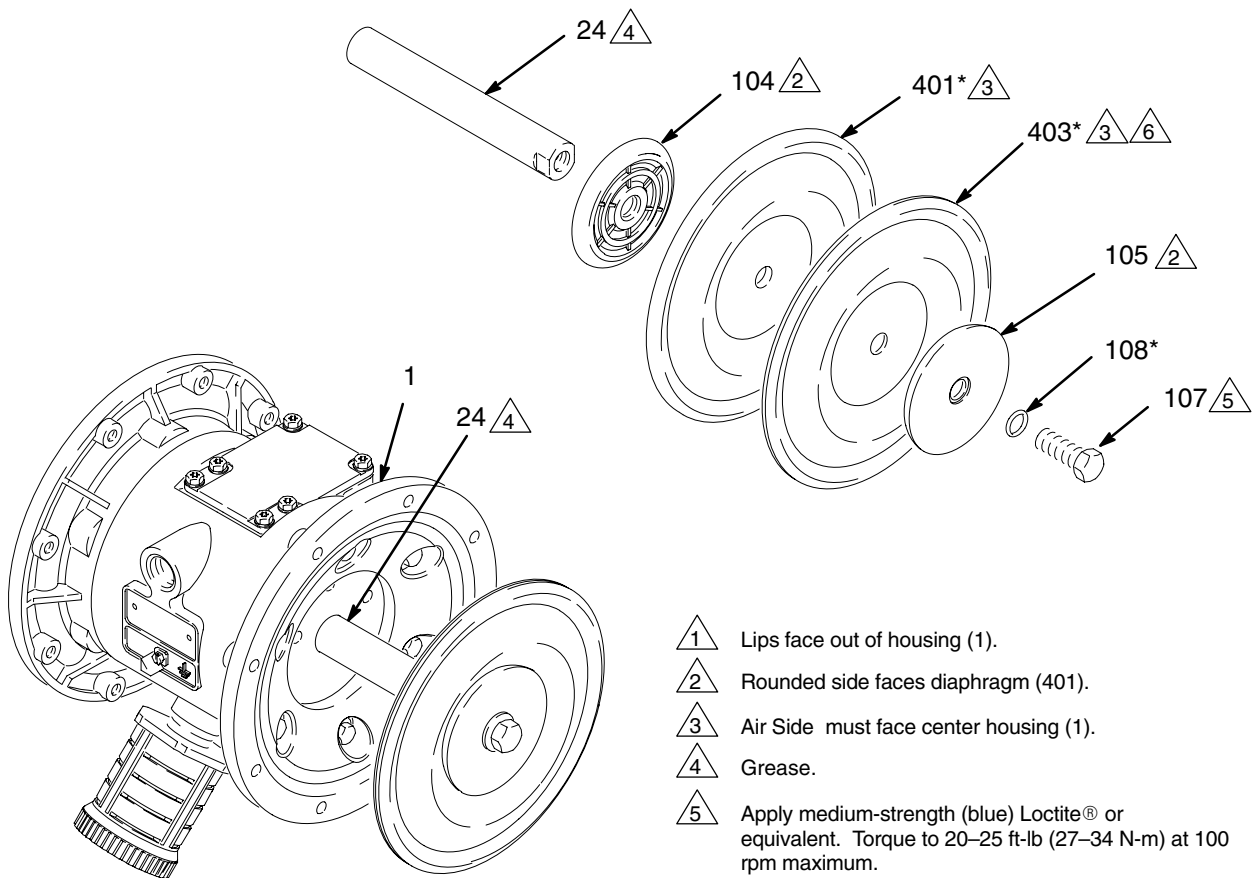

- △ 1 Lips face out of housing (1).
- △ 2 Rounded side faces diaphragm (401).
- △ 3 Air Side must face center housing (1).
- △ 4 Grease.
- △ 5 Apply medium-strength (blue) Loctite® or equivalent. Torque to 20–25 ft-lb (27–34 N-m) at 100 rpm maximum.
- △ 6 Used on pumps with PTFE diaphragms only.

Fig. 14

02636B

Service

Bearing and Air Gasket Removal

Tools Required

- Torque wrench
- 10 mm socket wrench
- Bearing puller
- O-ring pick
- Press, or block and mallet

Disassembly

NOTE: Do not remove undamaged bearings.

WARNING

To reduce the risk of serious injury whenever you are instructed to relieve pressure, always follow the **Pressure Relief Procedure** on page 12.

1. Relieve the pressure.
 2. Remove the manifolds and disassemble the ball check valves as explained on page 18.
 3. Remove the fluid covers and diaphragm assemblies as explained on page 19.
- NOTE:** If you are removing only the diaphragm shaft bearing (19), skip step 4.
4. Disassemble the air valve as explained on page 16.
 5. Using a 10 mm socket wrench, remove the screws (25) holding the air covers (23) to the center housing (1). See Fig. 15.
 6. Remove the air cover gaskets (22). Always replace the gaskets with new ones.
 7. Use a bearing puller to remove the diaphragm shaft bearings (19), air valve bearings (12) or pilot pin bearings (15). Do not remove undamaged bearings.
 8. If you removed the diaphragm shaft bearings (19) reach into the center housing (1) with an o-ring pick and hook the u-cup packings (402), then pull them out of the housing. Inspect the packings. See Fig. 14.

Reassembly

1. If removed, install the shaft u-cup packings (402*) so the lips face **out** of the housing (1).
2. The bearings (12, 15, and 19) are tapered and can only be installed one way. Insert the bearings into the center housing (1), **tapered end first**. Using a press or a block and rubber mallet, press-fit the bearing so it is flush with the surface of the center housing.
3. Reassemble the air valve as explained on page 16.
4. Align the new air cover gasket (22) so the pilot pin (16) protruding from the center housing (1) fits through the proper hole (H) in the gasket.
5. Align the air cover (23) so the pilot pin (16) fits in the middle hole (M) of the three small holes near the center of the cover. Install the screws (25), handtight. Apply medium-strength (blue) Loctite® or equivalent to the threads of the screws (25). See Fig. 15. Using a 10 mm socket wrench, torque the screws oppositely and evenly to 130–150 in-lb (15–17 N•m).
6. Install the diaphragm assemblies and fluid covers as explained on page 19.
7. Reassemble the ball check valves and manifolds as explained on page 18.

Service

- 1 Insert bearings tapered end first.
- 2 Press-fit bearings flush with surface of center housing (1).
- 3 Apply medium-strength (blue) Loctite® or equivalent. Torque to 130–150 in-lb (15–17 N•m).

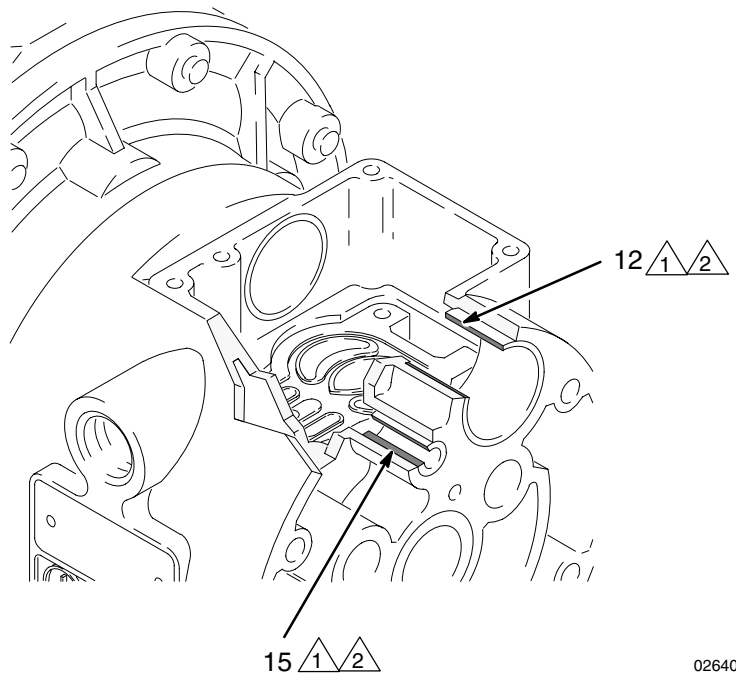

02640

Detail of Air Valve Bearings

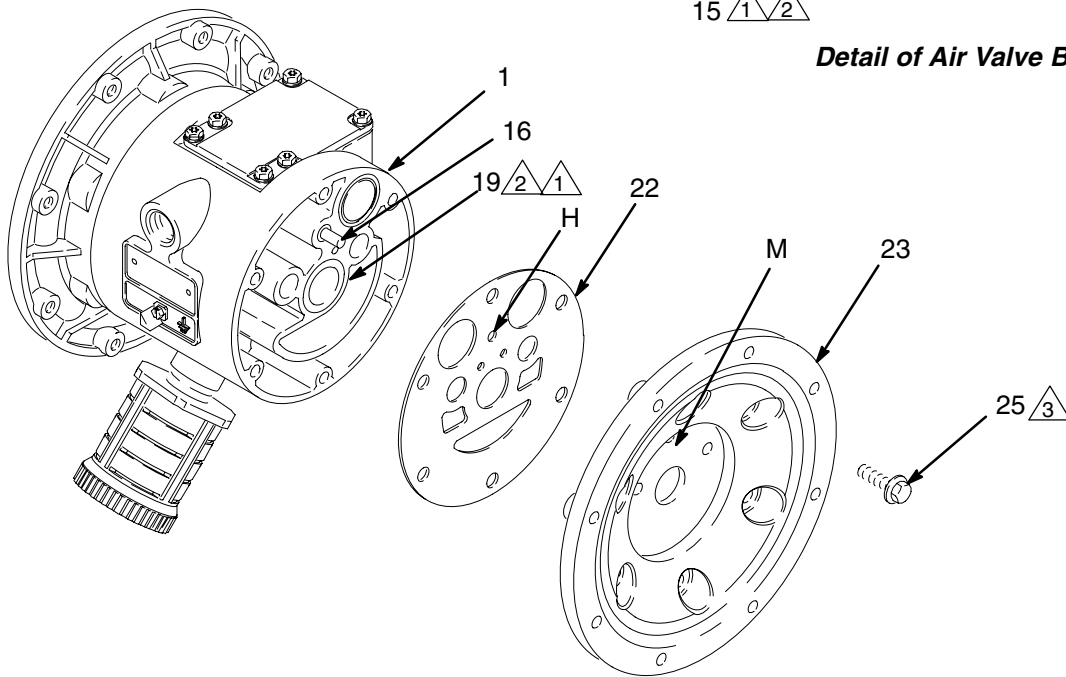

Fig. 15

02639B

Pump Matrix

Husky 1040 Aluminum and Stainless Steel Pumps, Series A

Your Model No. is marked on the pump's serial plate. To determine the Model No. of your pump from the following matrix, select the six digits which describe your pump, working from left to right. The first digit is always **D**, designating Husky diaphragm pumps. The remaining five digits define the materials of construction. For example, a pump with an aluminum air motor, aluminum fluid section, polypropylene seats, PTFE balls, and PTFE diaphragms is Model **D 7 3 9 1 1**. To order replacement parts, refer to the part lists on pages 28–30. *The digits in the matrix do not correspond to the ref. nos. in the parts drawing and lists.*

Diaphragm Pump	Air Motor	Fluid Section	–	Seats	Balls	Diaphragms
232501*	aluminum	aluminum	–	TPE	acetal	TPE
D (for all pumps)	7 Aluminum (Standard)	1 (not used)	–	1 (not used)	1 (PTFE)	1 (PTFE)
234124*	8 Aluminum (Remote)	2 (not used)		2 (acetal)	2 (acetal)	2 (not used)
246685*	R sst (standard)	3 (aluminum)	–	3 (316 sst)	3 (316 sst)	3 (not used)
24B779*	S sst (remote)	4 (sst)	–	4 (17–4 PH sst)	4 (440C sst)	4 (not used)
24B779*		5 (not used)	–	5 (TPE)	5 (TPE)	5 (TPE)
		C (aluminum BSPT)		6 (Santoprene®)	6 (Santoprene®)	6 (Santoprene®)
		D (sst BSPT)	–	7 (buna–N)	7 (buna–N)	7 (buna–N)
			–	8 (Fluoroelastomer)	8 (Fluoroelastomer)	8 (Fluoroelastomer)
			–	9 (polypropylene)	9 (not used)	9 (not used)
			–	A (PVDF)	A (not used)	A (not used)
			–	G (Geolast®)	G (Geolast®)	G (Geolast®)

* 232501, Aluminum 1040 Pump, Series D

Model No. 232501 is a private-label aluminum 1040 pump. This pump is the same as Model No. D73525 except for the label and:

Ref. Nos. 10 and 402 are 115666 Packing, U–cup, Fluoroelastomer

Ref. No. 17 is 168518 O–ring, Fluoroelastomer

Use 243492 as the Air Valve Repair Kit

Ref. 106 is 112178 SCREW, SST; M8 x 1.25; 25 mm

* 24B778 Stainless Steel Plus Pump

This pump is the same as Model DR4311 except for the serial plate and parts listed in the chart below.

* 24B779 Stainless Steel Pump

This pump is the same as Model D74311 except for the serial plate and parts listed in the chart below.

* 234124, Aluminum 1040 Pump, Series A

Model No. 234124 is a private-label aluminum 1040 pump. This pump is the same as Model No. D73GGG except for the label and:

Ref. Nos. 10 and 402 are 115666 Packing, U–cup, Fluoroelastomer

Ref. No. 17 is 168518 O–ring, Fluoroelastomer

Use 243492 as the Air Valve Repair Kit

* 26685, Aluminum 1040 Pump, Series A

Model No. 246685 is the same as Model No. D73331.

246450 Stainless Steel Air Motor Conversion Kit

Use kit 246450 and refer to manual 309643 (included in kit) to convert from aluminum air motor to stainless steel air motor.

Ref. No.	Part No.	Description	Qty
104	15H809	PLATE, air side; alum.	2
105	—	not used	0
107	—	not used	0
108	—	not used	0
401	15G744	DIAPHRAGM, HD, overmolded; PTFE/EPDM	2

Repair Kit Matrix

For Husky 1040 Aluminum and Stainless Steel Pumps, Series A

Repair Kits may be ordered separately. To repair the air valve, order **Part No. 236273** for aluminum center housing models or **Part No. 255061** for stainless steel center housing models (see page 30). Parts included in the Air Valve Repair Kit are marked with a symbol in the parts list, for example (4†■).

To repair your pump, select the six digits which describe your pump from the following matrix, working from left to right. The first digit is always **D**, the second digit is always **0** (zero), and the third is always **7**. The remaining three digits define the materials of construction. Parts included in the kit are marked with an asterisk in the parts list, for example (201*). For example, if your pump has polypropylene seats, PTFE balls, and PTFE diaphragms, order Repair Kit **D 0 7 9 1 1**. If you only need to repair certain parts (for example, the diaphragms), use the 0 (null) digits for the seats and balls, and order Repair Kit **D 0 7 0 0 1**. *The digits in the matrix do not correspond to the ref. nos. in the parts drawing and lists on pages 28–30.*

Diaphragm Pump	Null	Shaft O-ring	–	Seats	Balls	Diaphragms
D (for all pumps)	0 (for all pumps)	7 (PTFE)	–	0 (null)	0 (null)	0 (null)
			–	1 (not used)	1 (PTFE)	1 (PTFE)
			–	2 (acetal)	2 (acetal)	2 (not used)
			–	3 (316 sst)	3 (316 sst)	3 (not used)
			–	4 (17–4 PH sst)	4 (440C sst)	4 (not used)
			–	5 (TPE)	5 (TPE)	5 (TPE)
			–	6 (Santoprene®)	6 (Santoprene®)	6 (Santoprene®)
			–	7 (buna–N)	7 (buna-N)	7 (buna-N)
			–	8 (Fluoroelastomer)	8 (Fluoroelastomer)	8 (Fluoroelastomer)
			–	9 (polypropylene)	9 (not used)	9 (not used)
			–	A (PVDF)	A (not used)	A (not used)
			–	G (Geolast®)	G (Geolast®)	G (Geolast®)

Part No. 253626: Husky 1040 HD Overmolded PTFE/EPDM Diaphragm Repair Kit.

Part No. 289224: Husky 1040 HD Overmolded PTFE/EPDM Diaphragm Repair Kit, with new air side diaphragm plates.

Part No. 24F396: Husky 1040 PTFE/Santoprene Backer Overmolded Diaphragm Repair Kit

Parts

Air Motor Parts List (Matrix Column 2)

Digit	Ref. No.	Part No.	Description	Qty
7	1	188838	HOUSING, center; aluminum	1
	2	188854	COVER, air valve; alum.	1
	3	116344	SCREW, mach, hex flange hd; M5 x 0.8; 12 mm (0.47 in.)	9
	4†■	188618	GASKET, molded Santoprene	1
	5	188855	CARRIAGE; aluminum	1
	6†■	108730	O-RING; nitrile	1
	7†■	188616	BLOCK, air valve; acetal	1
	8	188615	PLATE, air valve; sst	1
	9†	188617	SEAL, valve plate;buna-N	1
	10†■	112181	PACKING, u-cup; nitrile	2
	11	188612	PISTON, actuator; acetal	2
	12	188613	BEARING, piston; acetal	2
	13≠	104765	PLUG, pipe; headless	2
	14≠	115671	FITTING, connector; male	2
	15	188611	BEARING, pin; acetal	2
	16	188610	PIN, pilot; stainless steel	2
	17†■	157628	O-RING; buna-N	2
	18†■	188614	BLOCK, pilot; acetal	1
	19	188609	BEARING, shaft; acetal	2
	20	116343	SCREW, grounding	1
	22	188603	GASKET, air cover; foam	2
	23	188839	COVER, air; aluminum	2
	24	188608	SHAFT, diaphragm; sst	1
	25	115643	SCREW; M8 x 1.25; 25 mm (1 in.)	12

Digit	Ref. No.	Part No.	Description	Qty
8	Same as 7 with the following exceptions			
	1	195921	HOUSING, center; aluminum, remote	1
	23	195917	COVER, air; remote	2
R	Same as 7 with the following exceptions			
	1	15K009	HOUSING, center; stainless steel	1
	2	15A735	COVER, air valve; stainless steel	1
	8■	15H178	PLATE, air valve; sst	1
	9	—	—	—
	23	15A736	COVER, air; stainless steel	2
	S	Same as 7 with the following exceptions		
1		15K011	HOUSING, center; remote, stainless steel	1
2		15A735	COVER, air valve; stainless steel	1
8■		15H178	PLATE, air valve; sst	1
9		—	—	—
23		15B794	COVER, air; remote, stainless steel	2

Parts

Fluid Section Parts List (Matrix Column 3)

Digit	Ref. No.	Part No.	Description	Qty
3	101	188840	COVER, fluid; aluminum	2
	102	188841	MANIFOLD, inlet; aluminum	1
	103	188842	MANIFOLD, outlet; aluminum	1
	104	188607	PLATE, air side; alum.	2
	105	188607	PLATE, fluid side; aluminum	2
	106	115643	SCREW; M8 x 1.25; 25 mm (1 in.)	24
	107	189044	BOLT; M12 x 1.75; 35 mm (1.38 in.); sst	2
	108*	104319	O-RING; PTFE	2
	110 ▲	188970	LABEL, warning	1
	111	112182	MUFFLER	1
	113	121497	PLUG: 1" npt; cst	4
	114	None	Not Used	0

Digit	Ref. No.	Part No.	Description	Qty
4	101	188860	COVER, fluid; sst	2
	102	188862	MANIFOLD, inlet; sst	1
	103	188861	MANIFOLD, outlet; sst	1
	104	188607	PLATE, air side; alum.	2
	105	188960	PLATE, fluid side; sst	2
	106	112178	SCREW; M8 x 1.25; 25 mm (1 in.)	24
	107	189044	BOLT; M12 x 1.75; 35 mm (1.38 in.); sst	2
	108*	104319	O-RING; PTFE	2
	110 ▲	188621	LABEL, warning	1
	111	112182	MUFFLER	1
	113	None	Not Used	0
	114	112257	NUT, hex; M8 x 1.25; sst	8

continued

Parts

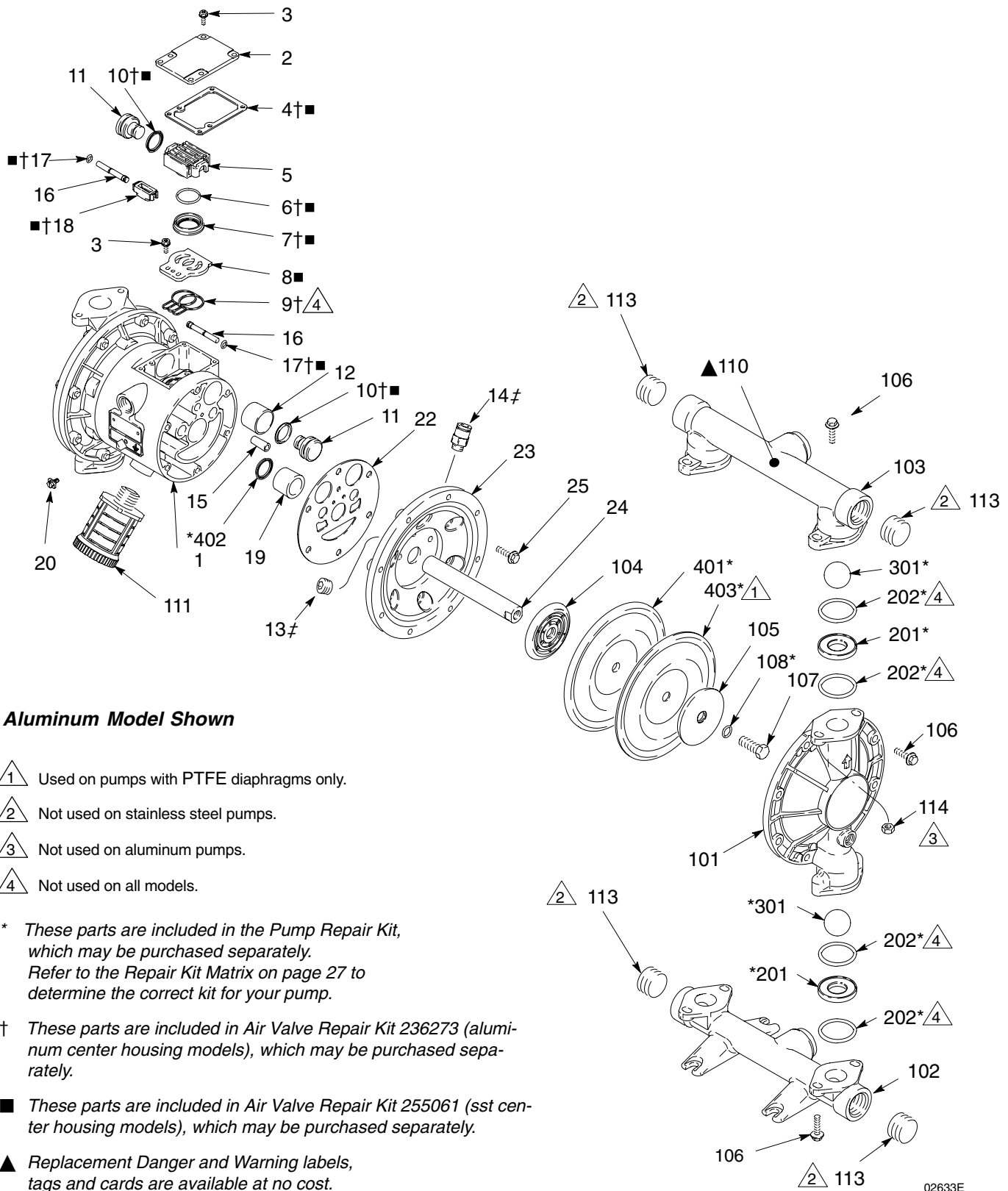

Aluminum Model Shown

- △1 Used on pumps with PTFE diaphragms only.
- △2 Not used on stainless steel pumps.
- △3 Not used on aluminum pumps.
- △4 Not used on all models.

* These parts are included in the Pump Repair Kit, which may be purchased separately. Refer to the Repair Kit Matrix on page 27 to determine the correct kit for your pump.

† These parts are included in Air Valve Repair Kit 236273 (aluminum center housing models), which may be purchased separately.

■ These parts are included in Air Valve Repair Kit 255061 (sst center housing models), which may be purchased separately.

▲ Replacement Danger and Warning labels, tags and cards are available at no cost.

‡ These parts are unique to remote piloted air motor, D8— and DS—

02633E

Parts

Fluid Section Parts List (Matrix Column 3)
(continued)

Digit	Ref. No.	Part No.	Description	Qty
C	101	188840	COVER, fluid; aluminum	2
	102	192070	MANIFOLD, inlet; aluminum; BSPT	1
	103	192071	MANIFOLD, outlet; aluminum; BSPT	1
	104	188607	PLATE, air side; aluminum	2
	105	188607	PLATE, fluid side; aluminum	2
	106	115643	SCREW; M8 x 1.25; 25 mm (1 in.)	24
	107	189044	BOLT; M12 x 1.75; 35 mm (1.38 in.); sst	2
	108*	104319	O-RING; PTFE	2
	110	188970	LABEL, warning	1
	▲			
	111	112182	MUFFLER	1
	113	113991	PLUG: 1" BSPT; cst	4
	114	None	Not Used	0
	D	101	188860	COVER, fluid; sst
102		192068	MANIFOLD, inlet; sst; BSPT	1
103		192069	MANIFOLD, outlet; sst; BSPT	1
104		188607	PLATE, air side; aluminum	2
105		188960	PLATE, fluid side; sst	2
106		112178	SCREW; M8 x 1.25; 25 mm (1 in.)	24
107		189044	BOLT; M12 x 1.75; 35 mm (1.38 in.); sst	2
108*		104319	O-RING; PTFE	2
110		188621	LABEL, warning	1
▲				
111		112182	MUFFLER	1
113		None	Not Used	0
114		112257	NUT, hex; M8 x 1.25; sst	8

Seat Parts List (Matrix Column 4)

Digit	Ref. No.	Part No.	Description	Qty
2	201*	188604	SEAT; acetal	4
	202*	109205	O-RING; PTFE	8
3	201*	188707	SEAT; 316 stainless steel	4
	202*	109205	O-RING; PTFE	8
4	201*	188708	SEAT; 17-4 stainless steel	4
	202*	109205	O-RING; PTFE	8
5	201*	188711	SEAT; TPE	4
	202	None	Not Used	0
6	201*	191595	SEAT; Santoprene	4
	202*	109205	O-RING; PTFE	8
7	201*	15B275	SEAT; Buna-N	4
	202*	None	Not used	0
8	201*	15B633	SEAT; fluoroelastomer	4
	202	None	Not Used	0
9	201*	189722	SEAT; polypropylene	4
	202*	109205	O-RING; PTFE	8
A	201*	189723	SEAT; PVDF	4
	202*	109205	O-RING; PTFE	8
G	201*	194211	SEAT; Geolast	4
	202*	109205	O-RING; PTFE	8

Parts

Ball Parts List (Matrix Column 5)

Digit	Ref. No.	Part No.	Description	Qty
1	301*	112088	BALL; PTFE	4
2	301*	112254	BALL; acetal	4
3	301*	103869	BALL; 316 stainless steel	4
4	301*	102973	BALL; 440C stainless steel	4
5	301*	112089	BALL; TPE	4
6	301*	112092	BALL; Santoprene	4
7	301*	15B488	BALL; buna-N	4
8	301*	15B487	BALL; fluoroelastomer	4
G	301*	114751	BALL; Geolast®	4

Diaphragm Parts List (Matrix Column 6)

Digit	Ref. No.	Part No.	Description	Qty
1	401*	Not sold separately	DIAPHRAGM, backup; polychloroprene (CR)	2
	402*	112181	PACKING, u-cup; nitrile	2
	403*	188605	DIAPHRAGM; PTFE	2
5	401*	188606	DIAPHRAGM; TPE	2
	402*	112181	PACKING, u-cup; nitrile	2
6	401*	188857	DIAPHRAGM; Santoprene	2
	402*	112181	PACKING, u-cup; nitrile	2
7	401*	15B499	DIAPHRAGM; buna-N	2
	402*	112181	PACKING, u-cup; nitrile	2
8	401*	15B500	DIAPHRAGM; fluoroelastomer	2
	402*	112181	PACKING, u-cup; nitrile	2
G	401*	194212	DIAPHRAGM; Geolast®	2
	402*	112181	PACKING, u-cup; nitrile	2

* These parts are included in the pump repair kit, purchased separately. See Repair Kit Matrix on page 27 to determine the correct kit for your pump.

Torque Sequence

Always follow torque sequence when instructed to torque fasteners.

1. Left/Right Fluid Cover
Torque Bolts to 120–150 in-lb (14–17 N•m)

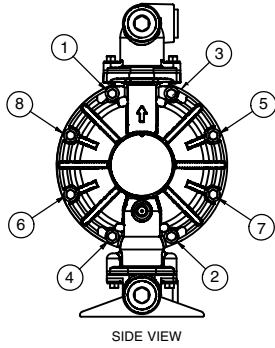

3. Outlet Manifold
Torque Bolts to 120–150 in-lb (14–17 N•m)

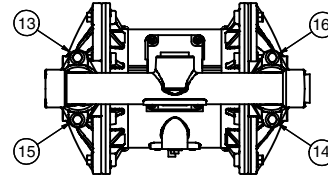

2. Inlet Manifold
Torque Bolts to 120–150 in-lb (14–17 N•m)

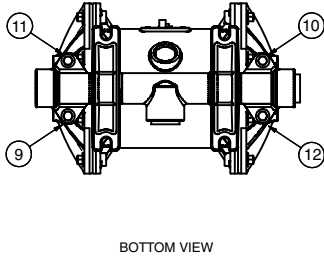

Dimensional Drawings

FRONT VIEW

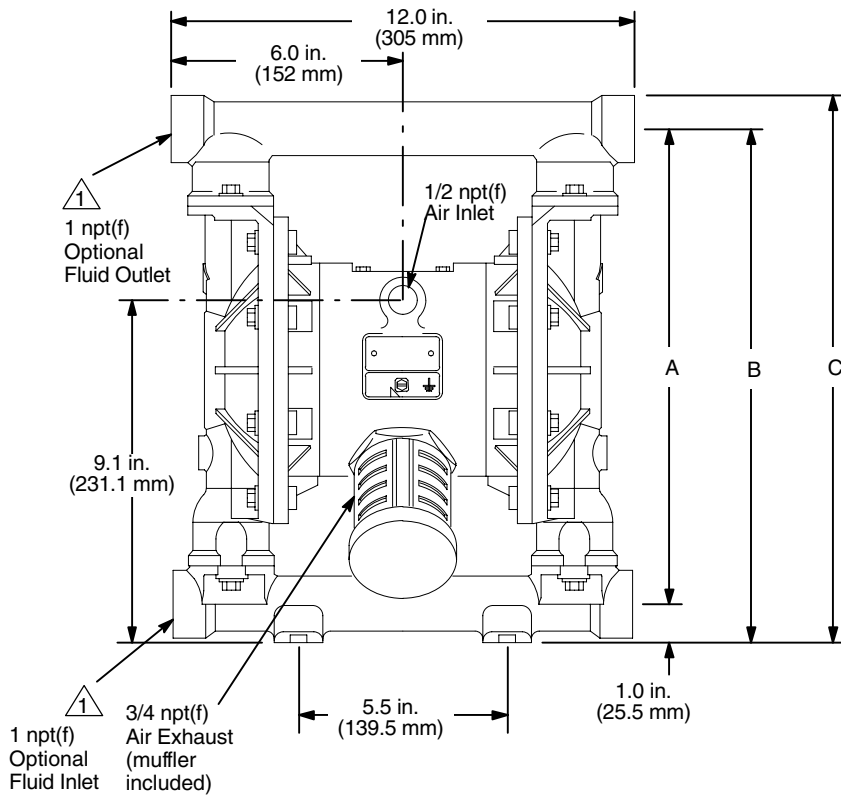

PUMP MOUNTING HOLE PATTERN

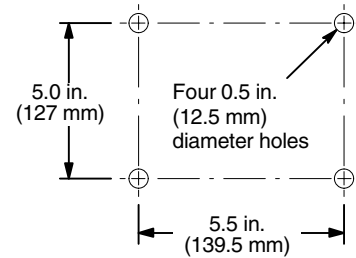

On aluminum pumps only.

7437A

SIDE VIEW

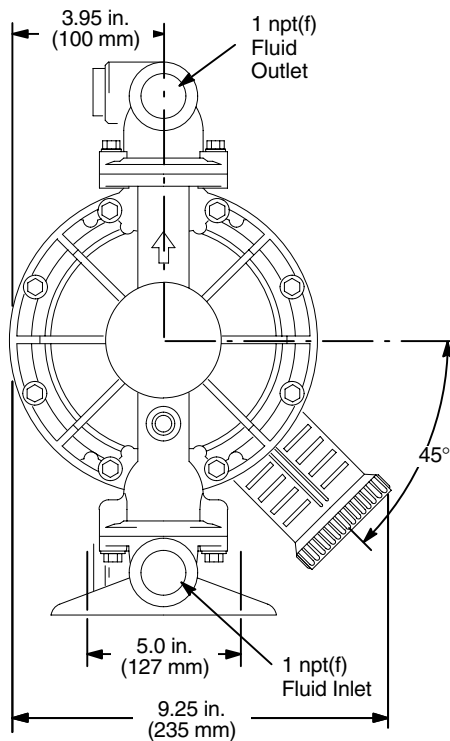

Dim.	Alum. Pumps	SST Pumps
A	12.58 in. (319.5 mm)	12.31 in. (312.7 mm)
B	13.58 in. (345.0 mm)	13.31 in. (338.1 mm)
C	14.48 in. (367.8 mm)	14.21 in. (360.9 mm)

Performance Chart

Test Conditions: Pump tested in water with inlet submerged.

Fluid Pressure Curves

- A** at 120 psi (0.7 MPa, 7 bar) operating air pressure
- B** at 100 psi (0.7 MPa, 7 bar) operating air pressure
- C** at 70 psi (0.48 MPa, 4.8 bar) operating air pressure
- D** at 40 psi (0.28 MPa, 2.8 bar) operating air pressure

To find Fluid Outlet Pressure (psi/MPa/bar) at a specific fluid flow (gpm/lpm) and operating air pressure (psi/MPa/bar):

1. Locate fluid flow rate along bottom of chart.
2. Follow vertical line up to intersection with selected operating air pressure curve.
3. Follow left to scale to read fluid outlet pressure.

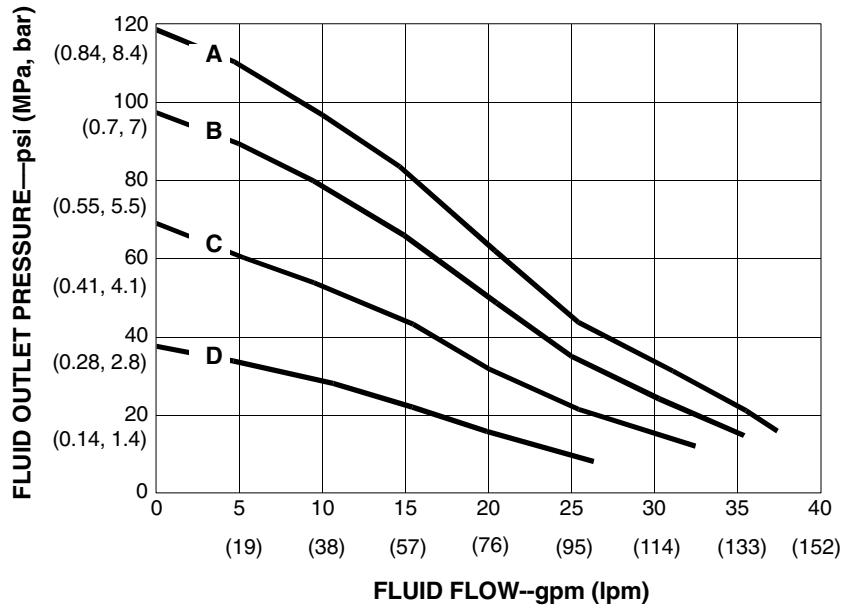

Air Consumption Curves

- A** at 120 psi (0.7 MPa, 7 bar) operating air pressure
- B** at 100 psi (0.7 MPa, 7 bar) operating air pressure
- C** at 70 psi (0.48 MPa, 4.8 bar) operating air pressure
- D** at 40 psi (0.28 MPa, 2.8 bar) operating air pressure

To find Pump Air Consumption (scfm or m³/min) at a specific fluid flow (gpm/lpm) and operating air pressure (psi/MPa/bar):

1. Locate fluid flow rate along bottom of chart.
2. Read vertical line up to intersection with selected operating air pressure curve.
3. Follow left to scale to read air consumption.

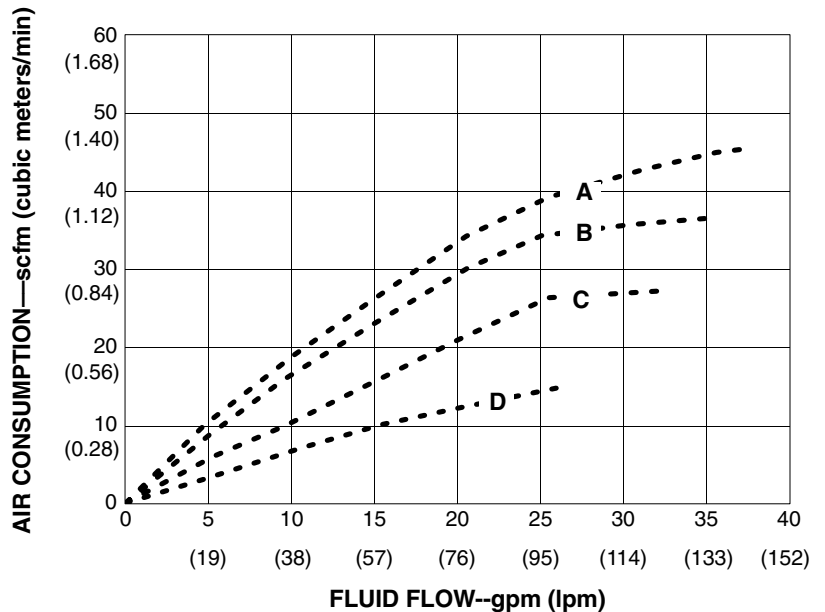

Technical Data

Maximum fluid working pressure	120 psi (0.8 MPa, 8 bar)
Air pressure operating range	20–120 psi (0.14–0.8 MPa, 1.4–8 bar)
Maximum air consumption	60 scfm
Air consumption at 70 psi/20 gpm	20 scfm (see chart)
Maximum free-flow delivery	42 gpm (159 l/min)
Maximum pump speed	276 cpm
Gallons (Liters) per cycle	0.15 (0.57)
Maximum suction lift	18 ft (5.48 m) wet or dry
Maximum size pumpable solids	1/8 in. (3.2 mm)
* Maximum Noise Level at 100 psi, full flow	89 dBA
* Sound Power Level	100 dBA
* Noise Level at 70 psi and 50 cpm	78 dBA
Maximum operating temperature	150°F (65.5°C); 200°F (93.3°C) for models with PTFE diaphragms
Air inlet size	1/2 npt(f)
Fluid inlet size	1" npt(f)
Fluid outlet size	1" npt(f)
Wetted parts	Vary by Model. See pages 28–30.
Non-wetted external parts	aluminum, 302, 316 stainless steel, polyester (labels)
Weight	
Aluminum pumps	18 lb (8.2 kg)
Stainless steel pumps with aluminum center section	33 lb (15.0 kg)
Stainless steel pumps with stainless steel center section	47 lb (22kg)

Geolast® and Santoprene® are registered trademarks of the Monsanto Co.

Loctite® is a registered trademark of the Loctite Corporation.

* Noise levels measured with the pump mounted on the floor, using Rubber Foot Kit 236452. Sound power measured per ISO Standard 9614–1.

Graco Warranties

Graco Standard Husky Pump Warranty

Graco warrants all equipment manufactured by Graco and bearing its name to be free from defects in material and workmanship on the date of sale to the original purchaser for use. With the exception of any special, extended, or limited warranty published by Graco, Graco will, for a period of five years from the date of sale, repair or replace any part of the equipment determined by Graco to be defective. This warranty applies only when the equipment is installed, operated and maintained in accordance with Graco's written recommendations.

This warranty does not cover, and Graco shall not be liable for general wear and tear, or any malfunction, damage or wear caused by faulty installation, misapplication, abrasion, corrosion, inadequate or improper maintenance, negligence, accident, tampering, or substitution of non-Graco component parts. Nor shall Graco be liable for malfunction, damage or wear caused by the incompatibility of Graco equipment with structures, accessories, equipment or materials not supplied by Graco, or the improper design, manufacture, installation, operation or maintenance of structures, accessories, equipment or materials not supplied by Graco.

This warranty is conditioned upon the prepaid return of the equipment claimed to be defective to an authorized Graco distributor for verification of the claimed defect. If the claimed defect is verified, Graco will repair or replace free of charge any defective parts. The equipment will be returned to the original purchaser transportation prepaid. If inspection of the equipment does not disclose any defect in material or workmanship, repairs will be made at a reasonable charge, which charges may include the costs of parts, labor, and transportation.

THIS WARRANTY IS EXCLUSIVE, AND IS IN LIEU OF ANY OTHER WARRANTIES, EXPRESS OR IMPLIED, INCLUDING BUT NOT LIMITED TO WARRANTY OF MERCHANTABILITY OR WARRANTY OF FITNESS FOR A PARTICULAR PURPOSE.

Graco's sole obligation and buyer's sole remedy for any breach of warranty shall be as set forth above. The buyer agrees that no other remedy (including, but not limited to, incidental or consequential damages for lost profits, lost sales, injury to person or property, or any other incidental or consequential loss) shall be available. Any action for breach of warranty must be brought within six years of the date of sale.

Graco makes no warranty, and disclaims all implied warranties of merchantability and fitness for a particular purpose in connection with accessories, equipment, materials or components sold but not manufactured by Graco. These items sold, but not manufactured by Graco (such as electric motors, switches, hose, etc.), are subject to the warranty, if any, of their manufacturer. Graco will provide purchaser with reasonable assistance in making any claim for breach of these warranties.

In no event will Graco be liable for indirect, incidental, special or consequential damages resulting from Graco supplying equipment hereunder, or the furnishing, performance, or use of any products or other goods sold hereto, whether due to a breach of contract, breach of warranty, the negligence of Graco, or otherwise.

FOR GRACO CANADA CUSTOMERS

The parties acknowledge that they have required that the present document, as well as all documents, notices and legal proceedings entered into, given or instituted pursuant hereto or relating directly or indirectly hereto, be drawn up in English. Les parties reconnaissent avoir convenu que la rédaction du présente document sera en Anglais, ainsi que tous documents, avis et procédures judiciaires exécutés, donnés ou intentés à la suite de ou en rapport, directement ou indirectement, avec les procédures concernées.

Extended Product Warranty

Graco warrants all Husky 205, 307, 515, 716, 1040, 1590, 2150, and 3275 air valve center sections to be free from defects in material and workmanship for a period of fifteen years from date installed in service by the original purchaser. Normal wear of items such as packings or seals are not considered to be defects in material and workmanship.