

Air-operated Hydraulic Pressure Jack  
AJ-50T3N  
(Operation instruction)

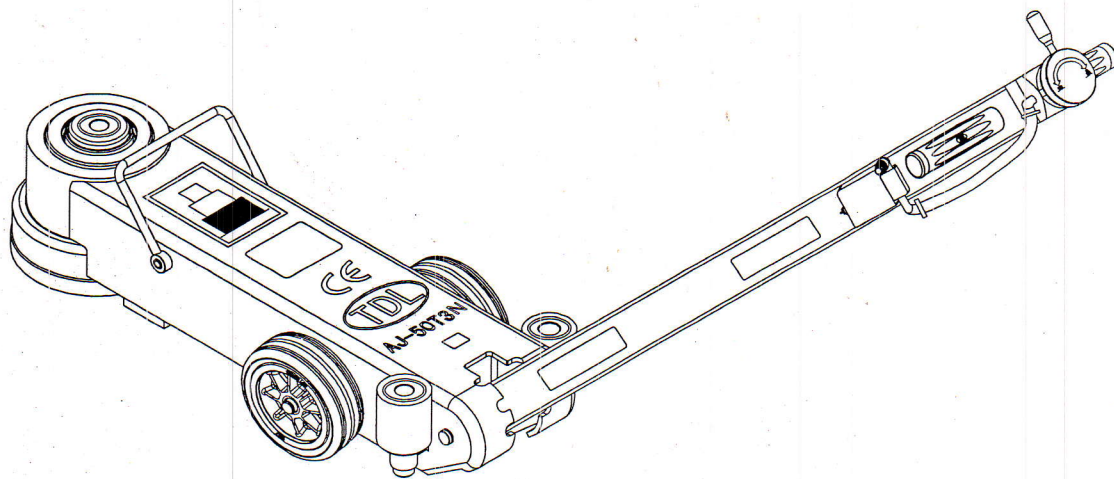

Minimum Height:150mm  
Hoisting Height:175mm

# WINDPIPE CONNECTION

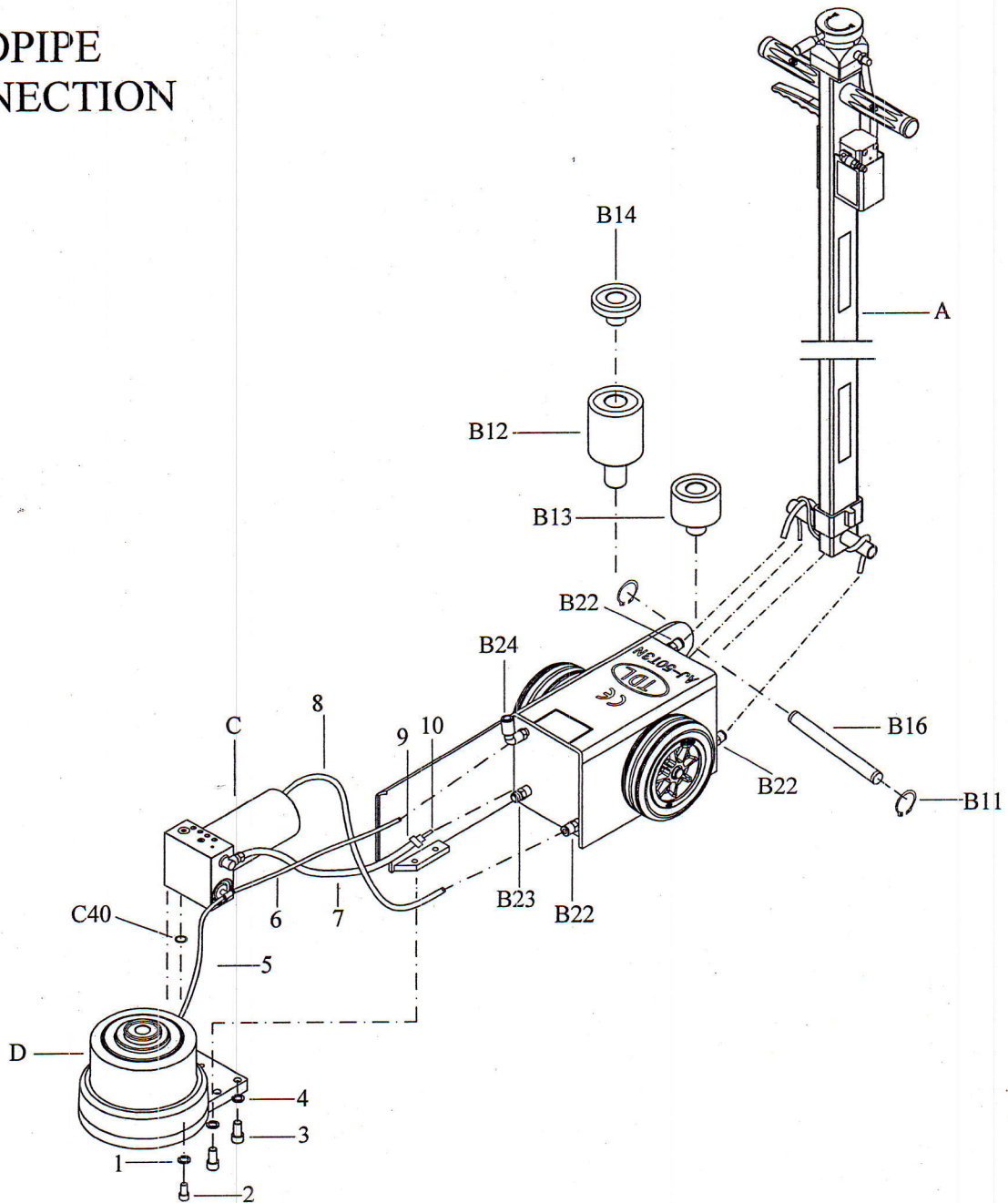

No.	PART NAME	QTY	No.	PART NAME	QTY	No.	PART NAME	QTY
1	M8 Spring Gasket	4	9	Lock Code	2	B22	Adaptor	3
2	M8 Screw	4	10	Adaptor	2	B23	Adaptor	1
3	M10 Screw	4	A	Operation Rod(1350mm)	1	B24	Adaptor	1
4	M10 Spring Gasket	4	B11	Outer Retainer Ring	2	C	Boosting System	1
5	Windpipe	1	B12	Extension Rod 80mm	1	C40	O Ring	1
6	Windpipe	1	B13	Extension Rod 40mm	1	D	50T3N Oil Cylinder	1
7	Oil Pipe	1	B14	Extension Rod 20mm	1			
8	Windpipe	1	B16	Fixed shaft	1			

AJ-50T3N EXPLODED VIEW  
Picture A

# Boosting System

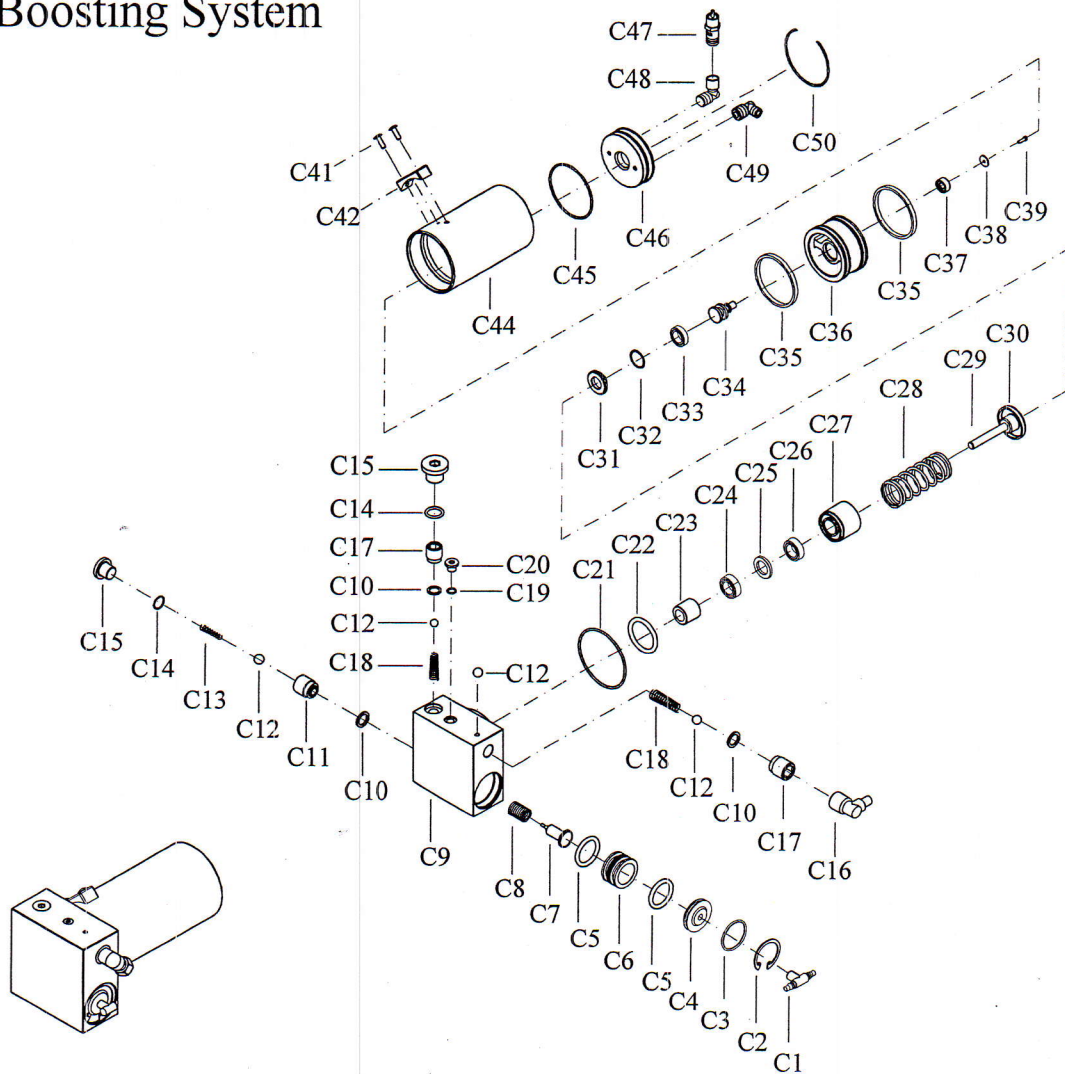

No.	PART NAME	QTY	No.	PART NAME	QTY	No.	PART NAME	QTY
C1	Adaptor	1	C17	Screw-plug	2	C33	Sealing kit	1
C2	Retaining Ring	1	C18	Spring	2	C34	Piston	1
C3	O Ring	1	C19	O Ring	1	C35	Gly Ring	2
C4	Fuel Return Piston Cover	1	C20	Screw-plug	1	C36	Piston	1
C5	O Ring	2	C21	O Ring	1	C37	Sealing Gasket	1
C6	Fuel Return Piston	1	C22	O Ring	1	C38	Sealing Gasket strength-point	1
C7	Fuel Return Thimble	1	C23	Shaft Sleeve of Hydraulic Pump	1	C39	Screw	1
C8	Fuel Return Spring	1	C24	IDI-11.2*21.2*8	1	C41	Screw	2
C9	Hydraulic Intergration	1	C25	Gasket of Hydraulic Pump	1	C42	Vent Cover	1
C10	Gasket	3	C26	IDI-11.2*19.2*5	1	C44	Boosting cylinder	1
C11	Screw-plug	1	C27	Hydraulic Pump	1	C45	O Ring	1
C12	Steel Ball	4	C28	Spring	1	C46	Cover	1
C13	Spring	1	C29	Piston rod	1	C47	Safe Valve	1
C14	O Ring	2	C30	Cover	1	C48	Adaptor	1
C15	Screw-plug	2	C31	Cover	1	C49	Adaptor	1
C16	Adaptor	1	C32	O Ring	1	C50	Retaining Ring	1

Boosting System Drawings  
Picture B

# AJ-50T3N Oil Cylinder

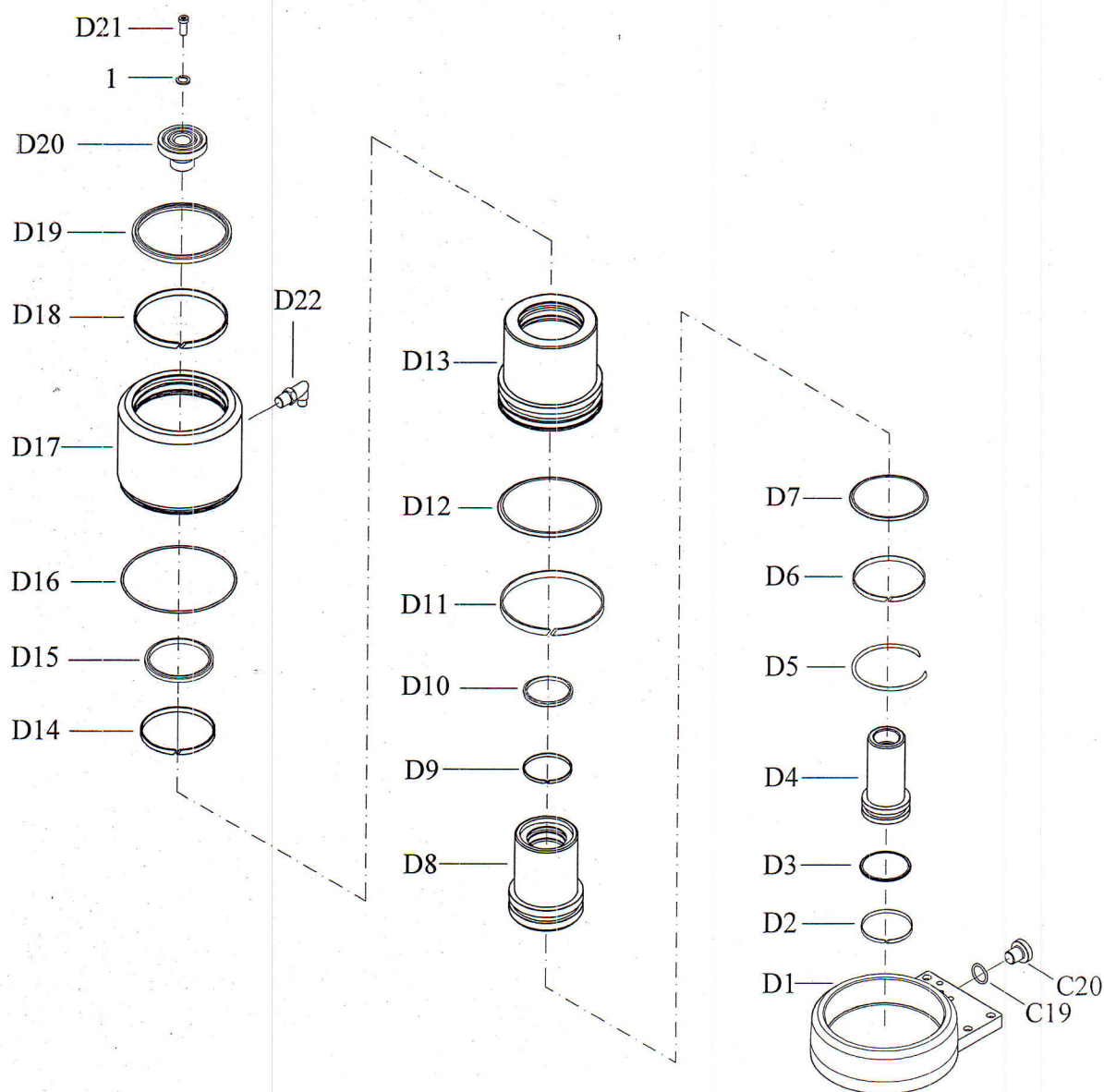

No.	PART NAME	QTY	No.	PART NAME	QTY	No.	PART NAME	QTY
1	M8 Spring Gasket	1	D7	Glyd Ring	1	D16	O Ring	1
C19	O Ring	1	D8	15TN Oil Cylinder	1	D17	50TN Oil Cylinder	1
C20	Screw-plug	1	D9	15TN Wearing Ring	1	D18	50TN Wearing Ring	1
D1	50TN Bottom	1	D10	Dustband	1	D19	Dustband	1
D2	15TN Wearing Ring	1	D11	50TN Wearing Ring	1	D20	Short Extension Rod	1
D3	Glyd Ring	1	D12	Glyd Ring	1	D21	Screw	1
D4	15TN Piston	1	D13	30TN Oil Cylinder	1	D22	Adaptor	1
D5	30TN Retaining Ring	1	D14	30TN Wearing Ring	1			
D6	30TN Wearing Ring	1	D15	Dustband	1			

Oil Cylinder Drawings  
Picture C

# AJ-50T3N Frame

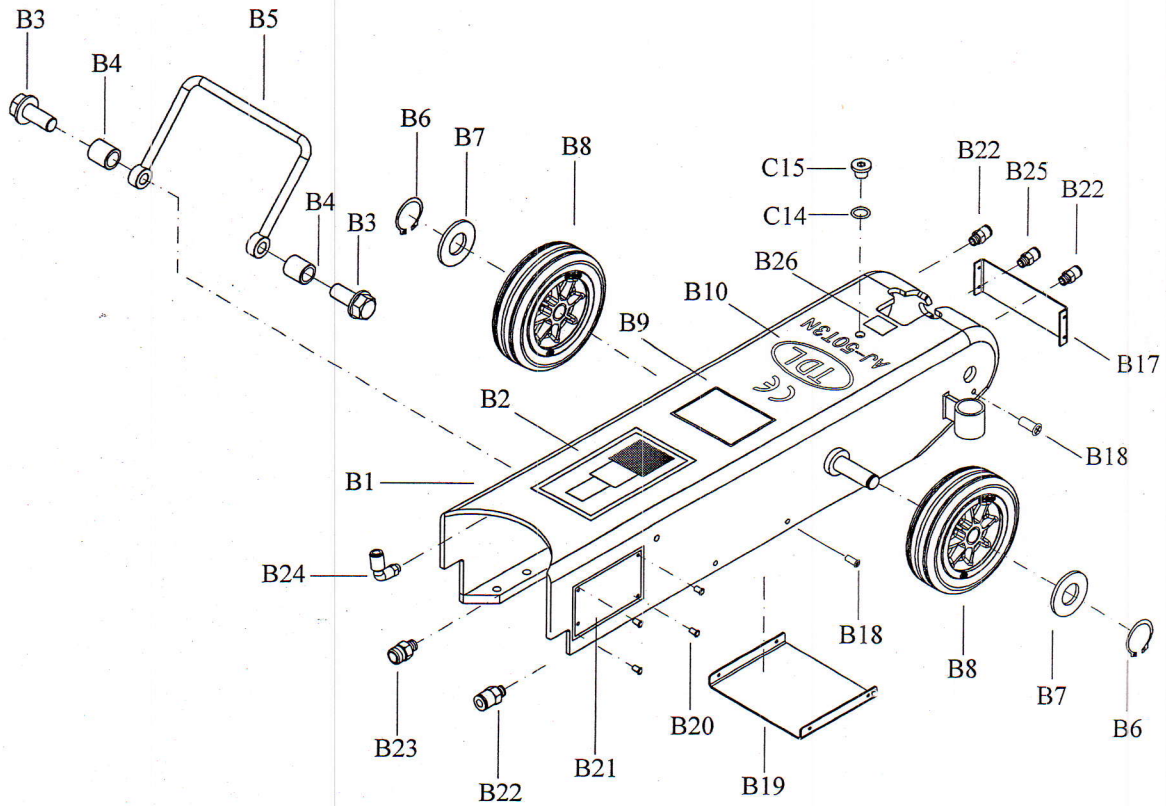

No.	PART NAME	QTY	No.	PART NAME	QTY
B1	Frame	1	B18	Screw	8
B2	Label	1	B19	Protected Plate	1
B3	screw	2	B20	Nail	4
B4	Screw-Plug	2	B21	Nameplate	1
B5	Handle	1	B22	Adaptor	3
B6	Outer Retainer Ring	2	B23	Adaptor	1
B7	Truckle Gasket	2	B24	Adaptor	1
B8	Truckle	2	B25	Adaptor	1
B9	Label	1	B26	Label	1
B10	Label	1	C14	O Ring	1
B17	Protected plate	1	C15	Screw-plug	1

Frame Drawings  
Picture D

### Operation Rod (1350mm)

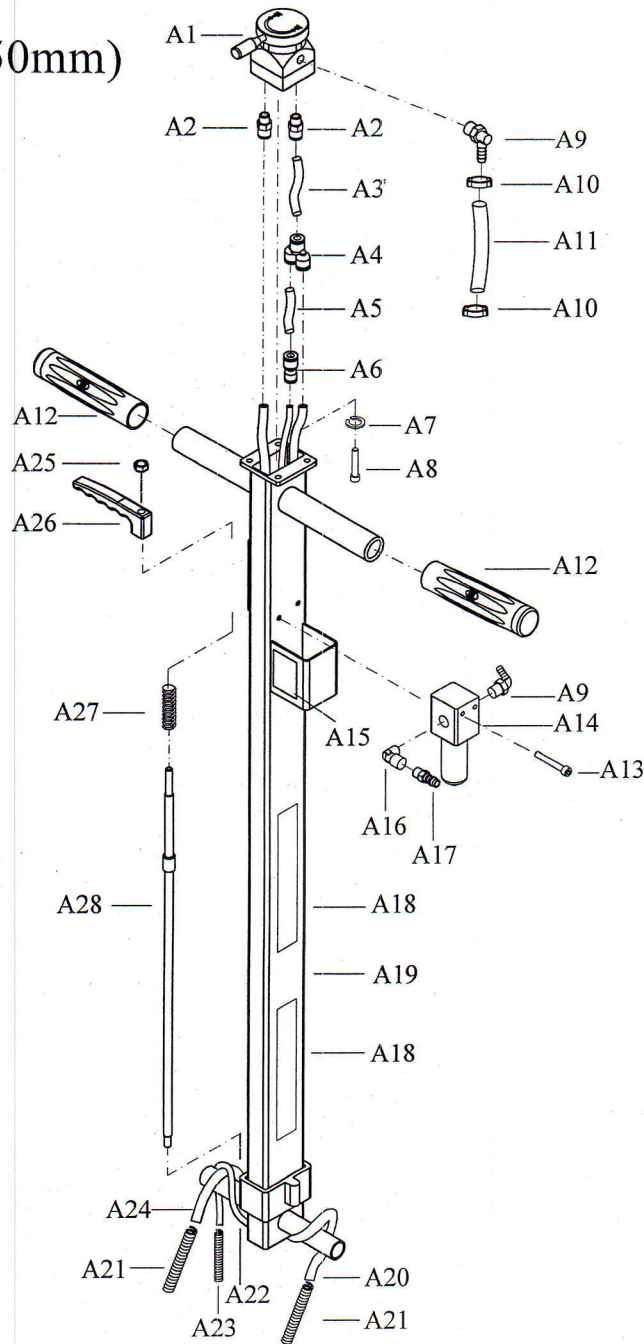

No.	PART NAME	QTY	No.	PART NAME	QTY	No.	PART NAME	QTY
A1	Hand Valve	1	A11	Oil Pipe	1	A21	Spring tube	2
A2	Adaptor	2	A12	Handle Cover	2	A22	Windpipe	1
A3	Windpipe	1	A13	Screw	2	A23	Spring tube	1
A4	Adaptor	1	A14	Filter	1	A24	Windpipe	1
A5	Windpipe	1	A15	Filter Instruction	1	A25	Screw	1
A6	Adaptor	1	A16	Adaptor	1	A26	Handle	1
A7	Spring Gasket	1	A17	Adaptor	1	A27	Spring	1
A8	Screw	2	A18	Label of Caution	1	A28	Long Rod	1
A9	Adaptor	2	A19	Frame of Operation Rod	1			
A10	Lock Code	2	A20	Windpipe	1			

Operation Rod Exploded View  
Picture E

# Hand Valve

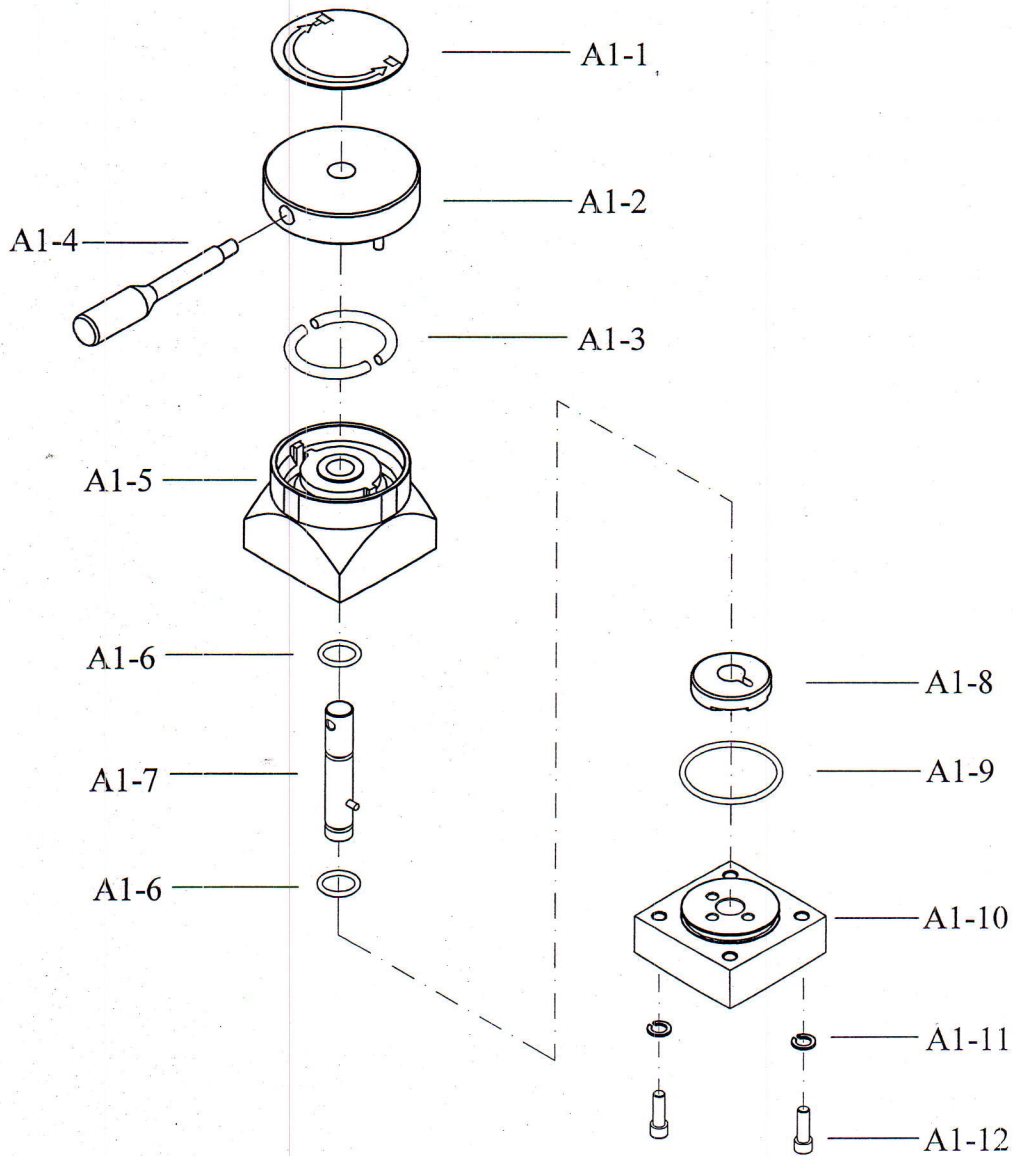

No.	PART NAME	QTY	No.	PART NAME	QTY
A1-1	Label	1	A1-8	Valve Core	1
A1-2	Cover of Hand Valve	1	A1-9	O Ring	1
A1-3	Return Spring of Hand Valve	2	A1-10	Conversion Base	1
A1-4	Controlling Handle	1	A1-11	Spring Gasket	2
A1-5	Cover of Reversing Valve	1	A1-12	Screw	2
A1-6	O Ring	2			
A1-7	Shaft	1			

Hand Valve  
Picture F